

SOME ECONOMICS OF WIRELESS COMMUNICATIONS

Yochai Benkler*

Prologue

Imagine that once upon a time the policymakers of the emerging British Empire believed that a nation's wealth came from the magnitude of its trade with distant nations. In pursuit of this belief, they set up the Imperial Trade Commission, which in turn decided that the way to optimize trade with India was to create the East India Company and give it a monopoly over trade with India. Along came Adam Smith, and classical economists began to understand that planned trade was inefficient. Competition among many would give rise to efficiency. After half a century or more of hemming and hawing, the Imperial Trade Commission decided to embark on a radical plan to introduce a market-based system for trade with India. It would eliminate the monopoly of the East India Company, and instead would create 1000 exclusive property rights to trade with India. These rights would be perfectly flexible, their owners could aggregate, divide, and sell the property right to East India trade as they wished. The Commission would hold one Big Bang auction, where all rights to trade with India would be auctioned at once, allowing efficient investment decisions and reducing gaming possibilities. A trade exchange would facilitate a robust, flexible, and efficient secondary market in these rights.

Just as the classical economists were at long last seeing their critique adopted, despite the opposition of the East India Company, a number of pesky neoclassical and new institutional economists began voicing some objections. The neoclassical economists would point out that "optimizing trade with India" was not a coherent definition of the goal of public policy in Britain. Optimizing welfare was the right goal, and there is no reason to think that a property system that optimized trade with India would necessarily be the best way to enhance welfare in Great Britain. The institutional economists would point out that property rights may or may not be efficient, depending on whether they were defined around the correct resource boundary. Following Ronald Coase, they might say that if the definition of the property rights did not follow at least approximately efficient boundaries of the resource used, transaction costs could cause the property system in question to be

* Professor of Law, New York University School of Law. Many of the insights in this article are the product of many conversations and email exchanges over the past 18 months with participants in the Open Spectrum Project, an ad hoc multidisciplinary group of academics, engineers from the industry, and policy experts. In particular my work has been influenced by Dewayne Hendricks, Andy Lippman, Larry Lessig, David Reed, Jerry Saltzer, and Tim Shepard.

persistently inefficient. In this case, they would muse, maybe there is no naturally bounded resource called “a right to trade with India,” and so there is no efficient delineation of property rights in trade. An *absence* of property rights, treating the “right to trade with India” as a commons open for all to take as they please, would be better. They might give it a catchy name, like, “free trade.”

The classical economists would protest, arguing that, without a shade of doubt, their system is preferable to the monopoly given the East India Company. And they would be right. They would argue that there is a finite number of trading partners available at any given time, and these will not be allocated efficiently unless we have a way of pricing the right to trade with them. They would argue that, if “free” trade is better than a market in exclusive trade rights, holders of trade rights would aggregate enough rights and then let anyone trade with India freely for some flat participation fee, or government bodies could buy trading rights and create free trade zones.

But we all know that they are wrong, do we not? Welfare and growth are the correct targets of economic policy, not trade with a particular trading partner. Free trade, *an absence of property rights* in the act of trading with India, is the correct economic solution, not a market in exclusive rights to trade, no matter how flexible or efficient. We do not believe that there is a naturally bounded resource called “the act of trading with India” whose contours could efficiently be delineated for clearance through property-based markets.

I. INTRODUCTION

For participants in the spectrum policy debate at the turn of the 21st century my little prolegomenon will sound a tendentious, but familiar, note. In the first half of the 20th century there was roughly universal agreement that “spectrum” was scarce, and that if it was to be used efficiently, it had to be regulated by an expert agency. A little over forty years ago, Coase wrote a seminal critique of this system, explaining why “spectrum scarcity” was no more reason for regulation than is “wheat scarcity.” “Scarcity” was the normal condition of all economic goods, and markets, not regulation, were the preferred mode of allocating scarce resources.¹ In the ‘60s and ‘70s a number of academic studies of property rights in spectrum elaborated on Coase’s work,² but these remained largely outside the pale of actual likely policy

¹ Ronald Coase, *The Federal Communications Commission*, 2 J of Law & Econ. 1 (1959).

² William K. Jones, *Use and Regulation of the Radio Spectrum: Report on a Conference*, 1968 Wash. L.Q.71 (1968); Arthur S. De Vany, Ross D. Eckert, Charles J. Meyers, Donald J. O’Hara, Richard C. Scott, *A Property System for Market Allocation of the Electromagnetic Spectrum: A Legal-Economic-*

options. It was only in the 1980s that a chairman of FCC voiced support for a system of market-base allocation,³ and only in the 1990s did Congress permit the FCC to use auctions instead of comparative hearings to assign spectrum.⁴ But auctions are but a pale shadow of real market-based allocation. Indeed, they might better be understood as a type of fee for government licenses than as a species of market allocation. Since the mid-1980s, and with increasing acceptance into the 1990s, arguments emerged within the FCC in favor of introducing a much more serious implementation of market-based allocation.⁵ This would call for the definition and auctioning of perpetual, exclusive property rights akin to those we have in real estate, which could be divided, aggregated, resold, and reallocated in any form their owners chose to do.

Just as this call for more perfect markets in spectrum allocations began to emerge as a real policy option⁶ a very different kind of voice began to be heard on spectrum policy. This position was every bit as radically different from the traditional approach as the perfected property rights approach, but in a radically different way. The argument was that technology had rendered the old dichotomy between government licensing of frequencies and property rights in frequencies obsolete. It was now possible to change our approach, and instead of creating and enforcing a market in property rights in spectrum blocks, we could rely on a market in smart radio equipment that would allow people to communicate without *anyone* having to control “the spectrum.” Just as no one “owns the Internet,” but intelligent computers communicate with each other using widely accepted sharing protocols, so too could computationally intensive radios. In the computer hardware and software markets and the Internet communications market, competition in the *equipment market*, not competition in the infrastructure market (say, between Verizon and AOL Time

Engineering Study, 21 Stan. L. Rev. 1499 (1969); Harvey J. Levin, *The Invisible Resource: Use and Regulation of the Radio Spectrum* (1971); and Jora R. Minasian, *Property Rights in Radiation: An Alternative Approach to Radio Frequency Allocation*, 18 J. Law & Econ. 221 (1975).

³ See Mark S. Fowler & Daniel Brenner, *A Marketplace Approach to Broadcast Regulation*, 60 Tex. L. Rev. 207 (1982) (Fowler was Chairman of the FCC under President Reagan). By the 1990s this position had become the mainstream, cutting across the political spectrum, as indicated by the remarks of FCC Chairman under President Clinton as well. Reed E. Hundt, *Remarks To Citizens For A Sound Economy Spectrum Policy and Auctions: What's Right, What's Left* (Washington, D.C. June 18, 1997) (Chairman of the FCC stating in his introduction that “for the first time ever the FCC truly follows a market-based approach to the allocation and use of spectrum.”)

⁴ See Pub. Law No. 103-66, 6001-02, 107 Stat. 379, 379-401 (1993).

⁵ See Evan R. Kwerel and Alex D. Felker, 1985, *Using Auctions to Select FCC Licensees*, OPP Working Paper No. 16 (May 1985); Evan R. Kwerel and John R. Williams, *Changing Channels: Voluntary Reallocation of UHF Television Spectrum*, OPP Working Paper No. 27 (November 1992); Gregory L. Rosston, Jeffrey S. Steinberg, *Using Market-Based Spectrum Policy to Promote the Public Interest* (OPP Working Paper 1997)

⁶ See, e.g., Spectrum Bill Discussion Draft: The Electromagnetic Spectrum Management Policy Reform And Privatization Act, CR, 104th Cong., S4928-4936 (May 9, 1996) (Senator Pressler)

Warner), was the driving engine of innovation, growth, and welfare. This approach has been called a “spectrum commons” approach, because it regards bandwidth as a common resource that all equipment can call on, subject to sharing protocols, rather than as a controlled resource that is always under the control of someone, be it a property owner, a government agency, or both.⁷ It is important to understand, however, that this metaphor has its limitations. Like its predecessor positions on spectrum management, it uses the term “spectrum” as though it describes a discrete resource whose utilization is the object of analysis. In fact, as this paper explains, “spectrum” is not a discrete resource whose optimal utilization is the correct object of policy. The correct object of optimization is wireless network communications capacity. Like trade with India, which is only one parameter of welfare in Britain, bandwidth is only one parameter in determining the capacity of a wireless network.

⁷ The policy implications of computationally intensive radios using wide bands were first raised, to my knowledge, by George Gilder in *The New Rule of the Wireless*, Forbes ASAP, March 29th, 1993, and by Paul Baran, *Visions of the 21st Century Communications: Is the Shortage of Radio Spectrum for Broadband Networks of the Future a Self Made Problem?* Keynote Talk Transcript, 8th Annual Conference on Next Generation Networks Washington, DC, November 9, 1994, available http://www.eff.org/pub/GII_NII/Wireless_cellular_radio/false_scarcity_baran_cngn94.transcript. Both statements focused on the potential abundance of spectrum, and how it renders “spectrum management” obsolete. Eli Noam was the first to point out that, even if one did not buy the idea that computationally intensive radios eliminated scarcity, they still rendered spectrum *property rights* obsolete, and enabled instead a fluid, dynamic, real time market in spectrum clearance rights. See Eli Noam, *Taking the Next Step Beyond Spectrum Auctions: Open Spectrum Access*, 33 IEEE Comm. Mag. 66 (1995); later elaborated in Eli Noam, *Spectrum Auction: Yesterday's Heresy, Today's Orthodoxy, Tomorrow's Anachronism. Taking the Next Step to Open Spectrum Access*, 41 J. Law & Econ. 765, 778-80 (1998). The argument that equipment markets based on a spectrum commons, or free access to frequencies, could replace the role planned for markets in spectrum property rights with computationally intensive equipment and sophisticated network sharing protocols, and would likely be more efficient even assuming that scarcity persists, is Yochai Benkler, *Overcoming Agoraphobia: Building the Commons of the Digitally Networked Environment*, 11 Harv. J. L & Tech. 287 (Winter 1997-98). Noam 1998, *supra*, and Yochai Benkler & Lawrence Lessig, *Net Gains: Is CBS Unconstitutional*, The New Republic (December 1998) suggested that the obsolescence of the controlled spectrum approach raises concerns as to whether the present licensing regime was unconstitutional as a matter of contemporary First Amendment law. Lawrence Lessig, *CODE* (1999) and Lessig, *THE FUTURE OF IDEAS* (2001) developed the argument that relied on the parallel structure of innovation in the original Internet end-to-end design architecture and of open wireless networks, offering a strong rationale based on the innovation dynamic in support of the economic value of open wireless networks. David Reed, *Why Spectrum is Not Property, The Case for an Entirely New Regime of Wireless Communications Policy* (February 2001) available at <http://www.reed.com/dprframeweb/dprframe.asp?section=paper&fn=openspec.html> and David Reed, *Comments for FCC Spectrum Task Force on Spectrum Policy*, filed July 10, 2002 and available at http://gullfoss2.fcc.gov/prod/ecfs/retrieve.cgi?native_or_pdf=pdf&id_document=6513202407 crystallized the technical underpinnings and limitations of the idea that spectrum can be regarded as property. Comments to the Task Force generally were the first substantial set of public comments in favor of a spectrum commons. Kevin Werbach, *Open Spectrum: The Paradise of the Commons*, Release 1.0 (November 2001) provided a crystallizing overview of the state of this critique and how it relates to the implementation of WiFi.

Focusing *solely* on it usually distorts the analysis. I will therefore mostly refer in this paper to “open wireless networks” rather than to spectrum commons. Like “the open road” or the “open architecture” of the Internet, it describes a network that treats some resources as open to all equipment to use, leaving it to the equipment manufacturers—cars or computers, respectively, in those open networks—to optimize the functionality they provide using that resource.

Most of the initial responses to this critique were largely similar to the responses that greeted the economists’ critique forty years ago—incomprehension, disbelief, and mockery,⁸ leading Noam to call the standard economists’ view “the new orthodoxy.”⁹ But reality has a way of forcing debates. The most immediate debate-forcing fact is the breathtaking growth of the equipment market in high-speed wireless communications devices, in particular the 802.11x or WiFi family of standards, all of which rely on utilizing frequencies that no one controls. Particularly when compared to the anemic performance of licensed wireless services in delivering high-speed wireless data services, and the poor performance of other sectors of the telecommunications and computer markets, the success of WiFi forces a more serious debate. It now appears that serious conversation between the two radical critiques¹⁰ of the licensing regime is indeed beginning to emerge, most directly joined now in a new paper authored by former chief economist of the FCC, Gerald Faulhaber, and Internet pioneer and former chief technologist of the FCC, Dave Farber.¹¹

What I hope to do in this paper is (a) provide a concise description of the baseline technological developments that have changed the wireless policy debate; (b) explain how these changes provide a critique of a spectrum property rights approach and suggest that open wireless networks will be more efficient at optimizing wireless communications capacity; and (c) outline a transition plan that will allow us to

⁸ See Thomas Hazlett, *Spectrum Flash Dance: Eli Noam's Proposal for "Open Access" to Radio Waves*, 41 J.L. & Econ. 805 (1998); Thomas Hazlett, *The Wireless Craze, the Unlimited Bandwidth Myth, the Spectrum Auction Faux Pas, and the Punchline to Ronald Coase's "Big Jokes: An Essay on Airwave Allocation Policy*, 14 Harv. J. L. & Tech. (Spring, 2001).

⁹ See Noam, 1998, *supra*.

¹⁰ It is important to understand that both critiques are radical, but neither is traditionally “left” or traditionally “right.” The property rights regime was initially a Reagan-era agenda, but has since been largely embraced by traditional left leaning media advocates who seek to use the money from the auctions for dedicated media-related spending. The commons regime has, from the very start, drawn support from across the political wing, engaging the imagination of both libertarians like George Gilder and progressives concerned with how communications policy affects democracy and social discourse, like Larry Lessig or myself.

¹¹ Gerald Faulhaber and David Farber, *Spectrum Management: Property Rights, Markets, and the Commons* (working paper). While still a working paper, even in its present form it is the first serious effort by proponents of spectrum property rights that has gone beyond mocking disbelief to evaluate the tradeoffs between property in spectrum and open wireless networks.

facilitate an experiment in both approaches so as to inform ourselves as we make longer term and larger scale policy choices in the coming decade.

To provide the economic analysis, I offer a general, though informal, model for describing the social cost of wireless communications, aggregating the equipment and servicing costs involved, the displacement of communications not cleared, and the institutional and organizational overhead in the form of transaction costs and administrative costs. In comparing these, I suggest that while investment patterns in equipment will likely differ greatly, it is not clear that we can say, *a priori*, whether equipment costs involved in an open wireless network will be higher or lower than equipment costs involved in spectrum property based networks. Investment in the former will be widely decentralized, and much of it will be embedded in end-user owned equipment that will capitalize *ex ante* the cost and value of free communications over the lifetime of the equipment. Investment in the latter will be more centrally capitalized because consumers will not invest both *ex ante* in capitalization of the value of free communication, and pay usage fees *ex post*. Since the value adding of spectrum property is in pricing usage to improve the efficiency of allocation over time, it will need lower *ex ante* investment levels at the end user terminal, and higher investment levels at the core of the network. Which of the two will have higher total cost over the lifetime of the network is not clear.

The most complicated problem is defining the relative advantages and disadvantages of spectrum property based networks and open wireless networks insofar as they displace some communications in order to clear others. Backing out of contemporary multi-user information theory, I propose a general description of the displacement effect of wireless communications. Then, I suggest reasons to think that open wireless networks will systematically have higher capacity, that is, that each communication cleared through an open network will displace fewer communications in total. This, in turn, leaves the range in which spectrum property based systems can improve on open wireless systems in terms of efficiency as those cases where the discriminating power of pricing is sufficiently valuable to overcome the fact that open wireless systems have cleared more communications but without regard to the willingness and ability of the displaced communications to pay. As a spectrum property based network diverges from locally and dynamically efficient pricing, the likelihood that it will improve efficiency declines.

As for overhead, or transaction and administrative costs, I suggest reasons to think that both direct transaction costs associated with negotiating transactions for spectrum and clearing transmission rights, and administrative costs associated with a property-type regime rather than an administrative framework for recognizing and generalizing privately-set equipment standards, will be lower for open wireless

networks. In particular, I emphasize how the transaction costs of a property system will systematically prevent efficient pricing, and therefore systematically undermine the one potential advantage of a spectrum property based system.

My conclusion is that the present state of our technological knowledge, and the relevant empirical experience we have with the precursors of open wireless networks and with pricing in wired networks, lean towards a prediction that open wireless networks will be more efficient in the foreseeable future. This qualitative prediction, however, is not sufficiently robust to permit us to make a decisive policy choice between the two approaches given our present limited practical experience with either. We can, however, quite confidently state the following propositions:

- Creating and exhaustively auctioning perfect property rights to all spectrum frequencies is an unfounded policy.
 - None of our technical, theoretical, or empirical data provides sufficient basis for belief that an exhaustive system that assigns property rights to all bands of frequencies will be systematically better than a system that largely relies on equipment-embedded communications protocols that are permitted to use bandwidth on a dynamic, unregulated basis.
- Creating such a property system will burden the development of computationally intensive, user equipment based approaches to wireless communications, potentially locking us in to a lower development trajectory for wireless communications systems.
 - This is particularly so for the dominant position that advocates creating perfect property rights in spectrum blocks, but is true even with modified systems, such as the Faulhaber-Farber proposal to include an easement for non-interfering transmissions or the Noam proposal of dynamic market clearance on the basis of spot-market transactions and forward contracts
- It is theoretically possible that pricing will sometimes improve the performance of wireless communications networks. The geographically local nature of wireless communications network capacity, the high variability in the pattern of human communications, and the experience of wired networks suggest, however, that if pricing will prove to be useful at all, it will be useful
 - Only occasionally, at peak utilization moments, and the cost benefit analysis of setting up a system to provide for pricing must consider the value of occasional allocation efficiency versus the cost of the drag on communications capacity at all other times

- It will be more useful if there are no property rights to specific bands, but rather all bandwidth will be available for dynamic contracting through an exchange system on the Noam model
- At most, the possibility of implementing pricing models suggests the creation of some spectrum for a real-time exchange alongside a commons. It does not support the proposal of a big bang auction of perfect property rights in all usable frequencies
- As a policy recommendation, it is too early to adopt a Big Bang approach to spectrum policy—either in favor of property or in favor of a commons. From a purely economic perspective, it would be sensible for current policy to experiment with both. What follows is a proposal that embodies a series of steps that could embody such an experiment. These are not analytically derived in the paper, but rather represent a distillation of the many conversations we have had in the Open Spectrum Project about alternative policy paths likely to be achievable and fruitful.¹²
 - Increasing and improving the design of the available spaces of free utilization of spectrum by intelligent wireless devices, so as to allow equipment manufacturers to make a credible investment in devices that rely on commons-based strategies
 - Dedicating space below the 2GHz range that would be modeled on one of two models
 - “Part 16/Meta-Part 68” equipment certification, with streamlined FCC certification processes; or
 - Privatized to a public trust that serves as a non-governmental standards clearance organization
 - A potential location for such a dedication is the 700 MHz band, where recently stalled efforts to auction the UHF channels suggest that there is resistance to their present auctioning, and where traditional dedication to the public interest would be an important basis for justifying the dedication to an infrastructure commons
 - Improving the U-NII Band regulations for the 5GHz range by designing the regulatory framework solely on the basis of the needs of open wireless networking, rather than, as now, primarily in consideration of protecting incumbent services. This would require

¹² This is not to suggest that all participants in the Open Spectrum Project agree on all steps, or that this paper represents a unified position. Responsibility for this particular distillation, and any errors it represents, rests entirely with me.

- Clearing those bands from incumbent services
- Shifting that band to one of the models suggested for the 2GHz range
- Permitting “underlay” and “interweaving” in all bands
 - Implementing a general privilege to transmit wireless communications as long as the transmission does not interfere with incumbent licensed devices
 - “Underlay” relates to what is most commonly discussed today in the name of one implementation—UWB—communications perceived as “below the noise floor” by the incumbent licensed devices, given their desired signal to interference ratios
 - “Interweaving” relates to the capability of “software defined” or “agile” radios to sense and transmit in frequencies only for so long as no one is using them, and to shift frequencies as soon as their licensed user wishes to use them
- Opening higher frequency bands currently dedicated to amateur experimentation to permit unregulated commercial experimentation and use alongside the amateur uses. This will allow a market test of the plausible hypothesis that complete lack of regulation would enable manufacturers to develop networks, and would lead them to adopt cooperative strategies
- Increasing the flexibility of current spectrum licensees to experiment with market-based allocation of their spectrum
 - This would include adoption of the modified property right proposed by Faulhaber and Farber for some incumbent licensees, and implementation of a scaled down auction of spectrum rights with structurally similar characteristics to the proposed Big Bang auction
- Both property rights sold and commons declared would be subject to a preset public redesignation option, exercisable no fewer than, say, 10 years after the auction or public dedication, to allow Congress to redesignate the spectrum from open to proprietary, or vice versa, depending on the experience garnered
 - Congress could, from time to time, extend the 10 year period, if it believes that the experiment is not yet decisively concluded, so as to preserve a long investment

- horizon for the firms that rely on either the proprietary or the open resource set
- The exercise date of the option would reflect the discount rate used by spectrum buyers for the property system and by equipment manufacturers for the commons, and will be set so as to minimize the effect of the redesignation right on present valuation of investments in buying spectrum or designing equipment for ownerless networks.
 - Experience built over time with these systems will teach us what mix of strategies our general long term approach should use: expanding commons-based techniques, expanding property rights in spectrum, or neither.

One important caveat is necessary before we continue. This paper looks at the problem of wireless communications from a purely technical-economic perspective. This is not to say that the economic perspective is the only one relevant to this debate. Quite the contrary, and I have often argued that open wireless systems are desirable from the perspectives both of democracy and autonomy.¹³ Needless to say, however, economics loom large in contemporary American policy debates in general and in spectrum policy debates in particular. My dedication of this paper to respond to these concerns does not, therefore, avoid the questions of political morality, but merely sets them aside for purposes of evaluating the internal economic argument. In general, my position has been that at least in the presence of persistent doubt about the comparative efficiency of the systems, a commitment to free and robust debate militates towards open wireless networks.

¹³ See Benkler, *Overcoming Agoraphobia*, supra; Yochai Benkler, *The Commons as a Neglected Factor of Information Policy*, (Telecommunications Policy Research Conference, September 1998); Benkler, *Siren Songs and Amish Children, Autonomy, Information and Law*, 76 NYU Law Rev. 23 (2001).

II. Open Wireless Networks: The Ideal Picture

Before going into the specific analysis of the technology and economics of open wireless networks, it is important that we have in mind a general image of what an open wireless network that no one owns would look like. Imagine that each piece of equipment can serve as either a transmitter or a receiver, either as user or as network component. In a town, imagine that the local school deploys a license-free wireless network as a low-cost solution to connecting its schools to each other and to the Internet. Individuals buy and install wireless devices on their computers for home connectivity. The local Blockbuster runs a video on demand server, the public library runs a public Internet access point, the bank an ATM, etc. With existing technology, such a network could deliver speeds faster than cable modems offer. The network would look roughly like Figure 1.

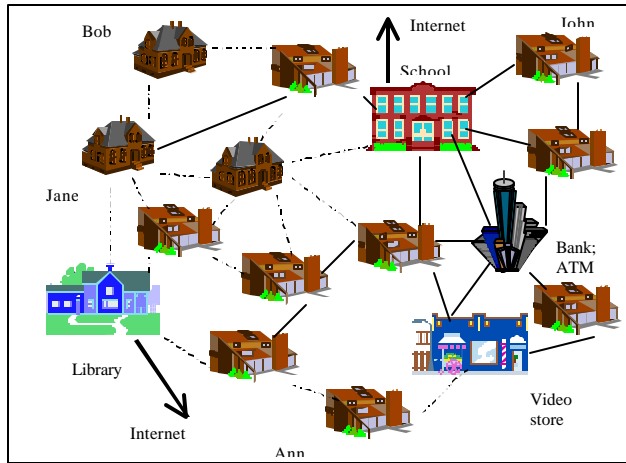

Figure 1: Ideal Open Wireless Network

The salient characteristics of such a network would be that it is

- Built entirely of end use devices
- Capable of being based entirely on an ad hoc infrastructure, with no necessity of any fixed infrastructure, although fixed infrastructure could be used if users or providers wanted to.
 - The point is that in such a network users could spontaneously create a network simply by using equipment that cooperates, without need for a network provider to set up its owned infrastructure as a precondition to effective communication
- Scalable (can grow to accommodate millions in a metropolitan area)
- Both mobile and fixed¹⁴

¹⁴ The list is derived from a list proposed by Andy Lippman at the first Open Spectrum Project meeting in May 2001. Lippman's list included that the equipment be simple to deploy, cheap for end users, and capable of allowing human beings to communicate with each other, with machines and for machines to

Imagining this network emerging is no longer a visionary exercise. It is possible with present technology, and future technological development is largely necessary to make it more efficient, not to enable its baseline plausibility. Looking at the world around us, we already see precursors of this kind of a network in WiFi networks and in commercial products like Nokia Rooftops or Motorola Canopy. What is preventing a major flowering of this model is a combination of intellectual commitment to “spectrum management”—whether by regulators or property owners—and entrenched interests, both expressed as tight legal prohibitions on the use of equipment that would lead to the emergence of such networks. The entrenched interests are those of incumbent licensees and government agencies, some protecting investments made in auctions, others protecting their ability to operate on their accustomed models without having to modernize. The purpose of this paper, of course, is to engage the intellectual opposition.

communicate with each other. As will become obvious in this paper, I make the cost of end user equipment endogenous to the communications model, and hence do not define its cost as a definitional pre-requisite of the system. I also do not include the specification of a wide range of uses, including non-human, not because I disagree that it would be a potentially good outcome, but because I do not see it as a definitional desideratum.

III. TECHNICAL BACKGROUND

The traditional model of wireless communications looks at the world through the eyes of a lone, stupid receiver. Stupid, because it is a receiver in whose eyes (or ears) all electromagnetic radiation is equal. It sees the world as a mass of radiation, undifferentiated except by the frequency of its oscillation, so that any given range of frequencies seems undifferentiated, as in Figure 2. Lone, because it does not seek or rely in any way on communications with other receivers, it simply waits for some source of radiation that is much more powerful than all other radiation that has a similar frequency, and it treats that radiation as a signal from a “transmitter,” which it then translates into human communication—audio, video, or text. A “signal,” that is to say a meaningful communication, occurs only when such a source is identifiably stronger than all these other sources of radiation. In Figure 3 this is represented by the spike in the center, which is then decoded by the receiver into humanly meaningful communication.

The problem of “interference” occurs when a receiver that is lone and stupid, and has such a simple picture of the world, encounters more than one source of powerful radiation that it tries to decode and cannot because, as in Figure 4, neither source is now sufficiently more powerful than *all* other sources of radiation. But “interference” is just a property of the

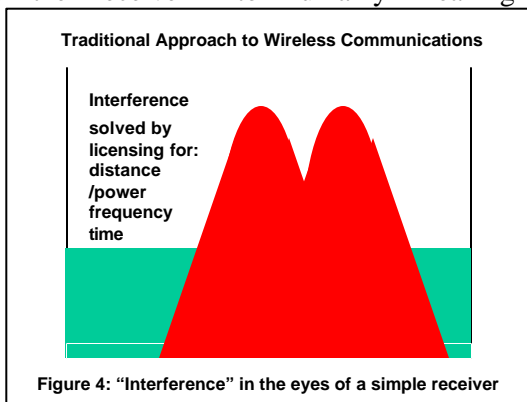
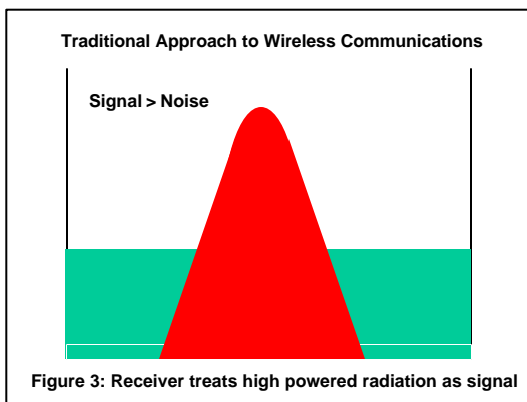
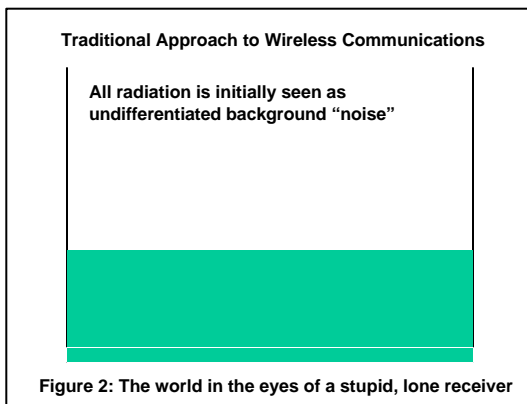

decoding model that the receiver uses, not of nature. The electromagnetic waves do not actually bounce off each other or “fall” to the ground before reaching the receiver’s antenna. “Interference” describes the condition of a stupid lone receiver faced with multiple sources of radiation that it is trying to decode but, in its simplicity, cannot. To solve this problem, we created and have implemented since 1912 a regulatory system that prohibits everyone from radiating electromagnetic waves at frequencies that we know how to use for communication, and then permits in individual cases someone, somewhere, to radiate within tightly regulated parameters of frequency, power, location, and timeframe, designed to permit the poor, lonely, stupid receivers to deliver to their human owners intelligible human messages.

This model was a reasonably good approximation of the practical characteristics of wireless communications networks given the high cost of computation and the conception of the relationship between terminals and networks that prevailed both in broadcast and in the switched telephone networks of the first half of the 20th century. That is, a computationally intensive machine was not really conceived before Turing in the 1930s, well after the regulatory framework we now have was created, and not really practical as a commercially viable end-user terminal until the early 1990s. The role of terminals in a network—be they radios or telephones—was largely to be dumb access points to a network whose intelligence resided at the core. The stupid lonely terminal, or receiver, was the correct assumption during this period, and it is what drove the picture of the world upon which both radio regulation and its property-based critique have been based ever since. If in fact all receivers can do to differentiate sources of radiation is to look at their frequency and relative power, and if the ability to listen for frequencies has to be hardwired into the circuits of the receiver, then from the perspective of the receiver there really are “channels” of “bandwidth” that correctly define the way the world is, in the only terms that that machine can perceive the world. It is also then true, as a practical matter, that if more than one person radiates in the “channel” the receiver cannot make head or tail of the message. And when this is the state of commercially available technology for almost a hundred years, we all begin to think of “the airwaves” as being divided into “channels” that can be used for various communications, but only if someone has an exclusive right to transmit. And it is this picture, embedded in our collective minds since our parents or grandparents sat and listened to the magical voices coming from the box in the 1920s, that underlies both current spectrum regulation and its spectrum property alternative.

The traditional model is no longer the most useful model with which to understand the problem of how to permit people to communicate information to each other electronically without being connected by wires. This is so because of one huge practical fact and two fundamental theoretical developments that have intervened

since the problem of radio regulation was imprinted on our collective minds. Together they mean that the stupid, lone receiver is the wrong starting point for wireless communications systems design, and hence for the institutional framework designed to support it.

The practical fact is the dramatic decline in the cost of computation. It means that receivers can use computationally intensive approaches for both signal processing and network communications to differentiate between different sources of electromagnetic radiation. No longer are frequency and power the two sole parameters that can be used, nor must any of the differentiating characteristics be hardwired into receivers.

The first theoretical development—Claude Shannon’s information theory—is over fifty years old.¹⁵ Among his innovations Shannon developed a formula to represent the information capacity of a noisy communications channel. His capacity theorem implies that there is an inverse correlation between the width of the band of frequencies of electromagnetic radiation that encodes information and the signal to noise ratio—that is, the power of the radiation that encodes the desired communication relative to other sources of radiation with a similar frequency when it reaches the receiver. The implication of this theory is that if a communication is sent using a sufficiently wide band of frequencies, the power of its signal need not be more powerful than the power of other sources of radiation. This implication was not practically usable for wireless communications until substantial computation became cheap enough to locate in receivers and transmitters, but it is now the basis of most advanced mobile phone standards, as well as of WiFi networks and other wireless systems.

What is crucial to understand about the implication of Shannon’s capacity theorem in particular, and his information theory more generally, is the concept of *processing gain*. “Gain” is used in radio technology to refer to a situation where, considering only the power at which the transmitter radiates its signal, the distance between the transmitter and the receiver, and the receiver’s required signal-to-interference ratio, the receiver would not be able to tell the difference between signal and noise, but something is done to the receiver or the transmitter, *other than increasing transmission power*, that makes the signal look to the receiver *as though* it were more powerful. Antenna gain—the use of a better or more sensitive antenna, is the most intuitively obvious form of gain. You can have bad reception, until you move your antenna, and then you get good reception. The transmitter did not increase

¹⁵ Claude E. Shannon, *A Mathematical Theory of Communication*, 27 Bell System Technical 379-423, 623-56 (1948).

power, but your use of the antenna created a perceived gain in signal strength. Processing gain relates to the same idea, but refers to using more complex encoding of the information, and the processing power necessary to decode it, rather than radiation power, to compensate for low transmission power.

A common approach for this is known as direct sequencing spread spectrum. A transmitter will take the message it intends to send, say, “Mary had a little lamb,” which in the traditional model would have been sent as the powerful signal described in Figure 3. Instead of sending the minimally complex code at the narrowest bandwidth, the transmitter adds more complex encoding, for example, adding xyz123... to each packet of data that makes up the message. It then sends this message over a wide band of frequencies, much wider than the minimal frequency bandwidth necessary purely to carry the actual message to a stupid receiver. As Figure 5 illustrates, because of Shannon’s theorem this allows the transmitter to send the message at much lower power than it would have

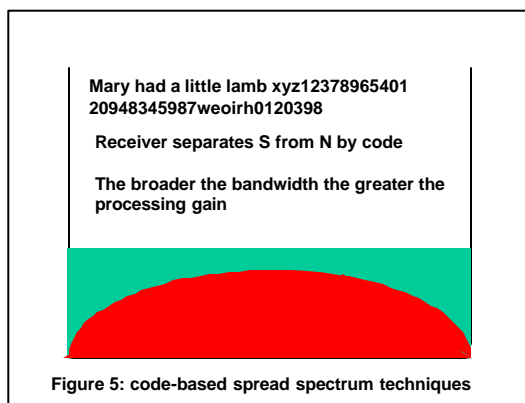

to use were it using a narrow channel—indeed, at such low power that it is no more powerful than other sources of radiation that, in the old model, would have been treated simply as background noise. The receivers, which are in fact computers, listen to very broad ranges of frequencies, and instead of differentiating between sources of radiation by their relative power they identify radiation patterns that coincide with the code that they know is associated with the transmission they are listening for. In our case, whenever a receiver listening for “Mary had a little lamb” perceives radiation that fits the code xyz123..., it treats that radiation as part of the message it is looking for. But it ignores “Mary” from the message “Mary Queen of Scots abc987....” In effect, the receivers used computation and complex encoding to create a “gain,” just like an antenna creates antenna gain, so that the weak signal is comprehended by the smart receiver to the same extent that a stupid receiver would have understood a much stronger signal in a narrow channel. This is called processing gain. Needless to say, the description oversimplifies and the technique I used to illustrate this point is only one of a number of techniques used to attain processing gain.¹⁶

¹⁶ This, however, has been hard to appreciate even for seasoned spectrum policy observers. In Hazlett’s extensive review of property rights in spectrum and criticism of open wireless approaches, for example, the author spends a number of pages criticizing the FCC for not moving quickly enough to permit

Processing gain poses a fundamental challenge to the prevailing paradigm, in that with processing gain there is no necessity that anyone be the *sole* speaker in a given “channel.” Many sources can radiate many messages at the same time over wide swaths of frequencies, and there may not be “interference” because the receivers can use techniques that are computationally intensive to differentiate one from the other. Just as video bit streams flow through a cable network past all houses connected to it, and are “received” or rejected by set-top boxes connected to that network based on encryption designed to allow the cable companies to charge, so too receivers scan the radio frequency range and pick out only those signals whose code shows that they are the intended message, rather than something else.

From a policy perspective, the most important thing to understand about processing gain is that it increases as bandwidth and computation available to a wireless network increase. The wider the band, the less power a transmitter-receiver pair needs in order for a receiver to understand the transmitter, but at the cost of more complex computation. Limiting the bandwidth of a signal, then, limits the processing gain a sender-receiver pair can achieve irrespective of how computationally sophisticated the equipment is. As more devices use a band, their low power builds up locally (their effect on unintended receivers rapidly declines as a function of distance from the transmitter), requiring all the proximate devices to increase their processing gain. With infinite bandwidth and costless computation, this would not present an efficient limit. With finite bandwidth and costly computation, increased information flow through a network will result in some social cost—either in terms of the cost of computation embedded in the equipment, or in terms of displaced communications—the communications of others who have less sophisticated equipment and cannot achieve the same processing gain. This means that the cost of computation and the permission to use wide swaths of spectrum are the limits on how many users can use a specified band with processing gain. Which will be the efficient limit will depend on the speed with which processors become faster and cheaper, relative to the extent to which bandwidth is made available for use in open networks. A perfect commons in all frequencies would mean that wireless networks could increase in capacity as a function of the rate of improvement of processors. A licensing or spectrum property regime will limit that growth when, and to the extent

Ultrawideband techniques that could be “the silver bullet that resolves spectrum congestion”. Hazlett, *Wireless Craze*, *supra* at 446-47. In another section, however, he spends a number of pages fending off the open wireless networks critique by arguing that spread spectrum techniques are “not new, not unique.” [working paper at 132-34] and do not really change anything fundamental. The two techniques—UWB and DSSS—are, however, simply different techniques for implementing exactly the same information theoretic principle, and the two statements are therefore internally inconsistent.

that, those who control frequencies release them to open wireless network use more slowly than the rate of growth in computation capabilities of user equipment.

The second theoretical development that works in conjunction with Shannon's theory is tied to the evolution of networked communications that accompanied the development of the Internet, and of work done to improve the efficiency of cellular systems under the rubric of multi-user information theory.¹⁷ This work suggests that, independent of processing gain, there is another source of "gain" that every receiver can get from being part of a network of receivers, rather than being a lone receiver. David Reed has described this gain as *cooperation gain*, and has been the most important voice in focusing the public policy debate on the potential of this type of gain to scale capacity proportionately with demand.¹⁸ In multi-user information theory it has been called *diversity gain*.¹⁹ This includes both the value added by repeater networks²⁰ and the information value that multiple receivers can gain by cooperating to help each other detect signals.²¹

The most intuitive form of cooperation gain is the effect that adopting a repeating, mesh architecture has on the capacity of a wireless communications network. Looking back to the work of Shepard in 1995,²² it is possible to use the architecture of a network of radios to limit the total power output of a system of wireless devices. This is important because, as I explained above, the computational complexity of attaining processing gain increases as the total power emitted by all transmitters in a locality increases. The efficiency of a wireless communications system can therefore be improved if the total power output of the system is reduced,

¹⁷ See, e.g., S. Verdu *MULTIUSER DETECTION* (Cambridge U. Press 1998); D.N.C. Tse and S.V. Hanly, *Linear Multiuser Receivers: Effective Interference, Effective Bandwidth, and User Capacity*, 45(2) IEEE Transactions on Information Theory, 641-57 (1999); S.V. Hanly, *Information Capacity of Radio Networks* (PhD thesis, Cambridge University, 1993); M Honig, U. Madhow, and S. Verdu, *Blind Adaptive Multiuser Detection*, 44 IEEE Transactions on Information Theory (No. 2 1996); Tse & Hanly, *Effective Bandwidths in Wireless Networks with Multiuser Receivers*; S. V. Hanly and P. Whiting, *Information Theoretic Capacity of Multi-Receiver Networks* (1994); R. Knopp and P.A. Humblet, *Information Capacity and power control in single-cell multi-user communications*, in Proc. Int'l Conf. On Communications (Seattle, 1995); P. Gupta and P. R. Kumar, *The Capacity of Wireless Networks*, IEEE Transactions on Information Theory, 46(2) 388 (March, 2000).

¹⁸ Reed, Comments, *supra*.

¹⁹ See, e.g., Tse & Hanly, *supra*, Grossglauser & Tse; Hanly & Whiting 1993, *supra*.

²⁰ The first model for practical implementation of this approach was Timothy Shepard, *Decentralized Channel Management in Scalable Multi-hop Spread Spectrum Packet Radio Networks*, PhD Dissertation, MIT 1995). Information theoretical work includes Knopp and Humblet, *supra*; Gupta & Kumar, *supra*; Matthias Grossglauser and David Tse, *Mobility Increases the Capacity of Ad Hoc Wireless Networks*.

²¹ See Verdu, *supra*.

²² Shepard, *supra*, and Timothy J. Shepard, *A Channel Access Scheme for Large Dense Packet Radio Networks*, Proc. ACM SIGCOMM '96 (San Fransisco 1996).

thereby simplifying the sharing problem for all users, and allowing more information to flow accurately through the system given a set level of investment in the computational intensity of the user devices. At the simplest level, consider the ideal network I described before, and imagine that Bob wants to talk to the Bank, while Jane wants to talk to the Video Store. Ignore for a moment processing gain. In the traditional model, they would each have had to radiate with enough power to reach their destination. Because they are closer to each other than to their destination, they would not have been able to do so at the same frequency. In a repeating network, however, neither need radiate at that high power. Instead, each need only reach a neighbor who can further relay the message with several low power hops, none of which is powerful enough to interfere with the parallel path of hops used by the other. Thus, even without processing gain, the two messages could have used the same frequency. This is precisely the rationale of adding cells to a cell phone network in order to increase the number of people who can communicate over the same set of frequencies by “reusing spectrum”. The thing to understand is that, just as adding cells to a cell phone network adds capacity to the same band of frequencies, but at the cost of added complexity in network management, so too adding *users* to an open wireless network can *add capacity*, not only demand. But adding cell towers means adding infrastructure to support more users, which is not counterintuitive. The notion that adding users—those who are the source of increased demand for capacity—itself also adds capacity is thoroughly counterintuitive. It shifts the question of network design from one of building enough infrastructure to support x number of users, to one concerned with a particular Holy Grail—how to design the equipment and the network so that users add capacity at least proportionately to their added demand. If a network can be designed so that each user can add at least as much capacity as he or she requires from the network, then adding the user to the network is costless except for the cost of the equipment.

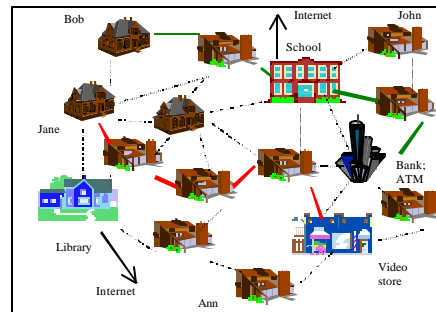

Figure 6: Network with repeaters minimizing power

Multi-user information theory more generally suggests that there are many techniques for increasing the capacity of a network of users by relying on cooperation among an increasing number of nodes in the network, both as repeaters to lower power output, and as receivers. Grossglauser and Tse show that mobile ad hoc systems can use the mobility of nodes as a way of improving the capacity of a system to the point where capacity for applications that are latency-insensitive actually does increase proportionately with nodes. That is, adding nodes does not actually reduce *anyone's* capacity to use the system for the limited case of latency insensitive

communications.²³ This can also take the form of designing the network so that all users know the structure of the signal of all the users, allowing each unit to treat radiation sent by other units not as background white noise that it must overcome by a complex encoding process, but as identifiably unrelated radiation that can be filtered out more simply. Tse & Hanley, for example, describe a minimum mean square (MMSE) receiver that increases capacity of a network precisely by using the structure of radiation from other transmitters.²⁴ Zheng and Tse have shown that using an array of antennas that use the phenomenon of multi-path—a major source of “interference” in the traditional model—as a source of information, can create an effect based on spatial diversity that is parallel to processing gain.²⁵ Laneman, Tse and Wornell have shown that a distributed ad hoc network of receivers can replicate the efficiencies of an antenna array without the need for physical arrays.²⁶ This body of work shows quite clearly that repeater networks and multi-user detection can be achieved in ad hoc networks, and that cooperation gain can be attained efficiently without a network owner providing centralized coordination.

In combination, these two effects—processing gain and cooperation or diversity gain—convert the fundamental question of “spectrum management”—how to use a finite and fixed resource—into a different fundamental question. The basic point to see is that “spectrum”—the bandwidth of the frequencies used to communicate—is not an independent and finite resource whose amount needed for a communication is fixed prior to the act of communicating, and to which property rights can be affixed so that it is efficiently allocated among communications. Bandwidth is one important parameter in an equation that includes radiation power, processing power of receivers and transmitters, bandwidth, and network architecture. Different configurations of these parameters are possible: some will invest more in signal processing, some in network design, some in utilization of specified bandwidth. An approach to policy that assumes that bandwidth is “the resource” whose regulation needs to deliver the socially desirable outcome of efficient wireless communications ignores and burdens a whole set of strategies to providing the functionality of wireless communication that rely on intensive use of computation and network architecture, rather than on bandwidth intensive usage. The basic economic policy choice we now face is whether wireless communications will be better optimized through the implementation of wireless communications systems designed to scale capacity to

²³ Matthias Grossglauser and David Tse, *Mobility Increases the Capacity of Ad Hoc Wireless Networks*.

²⁴ Tse & Hanly, *Effective Bandwidths in Wireless Networks with Multiuser Receivers*.

²⁵ Lizhong Zheng and David N.C. Tse, *Diversity and Multiplexing, A Fundamental Tradeoff in Multiple Antenna Channels* (working paper 2002)

²⁶ J. Nicholas Laneman, David N.C. Tse, and Gregory W. Wornell, *Cooperative Diversity in Wireless Networks, Efficient Protocols and Outage Behavior*, forthcoming IEEE Transactions on Information Theory(2002).

meet demand dynamically and locally, or by systems based on licensing or spectrum property rights, designed, at best, more efficiently to allocate capacity that is either fixed in the short term or grows slowly.

IV. CAPACITY GROWTH AND ALLOCATION IN WIRELESS COMMUNICATIONS SYSTEMS

While it is common to talk about optimizing “spectrum use,” then, a more neutral definition of what we should optimize is *the capacity of users to communicate information without wires*. Focusing on “spectrum” leads one to measure how many bits are being transmitted per herz per meter. As Part III explains, this is only one, relatively simple and inefficient way of describing the problem of how to allow people to communicate information without wires. The question that must be answered is whether there are any systematic reasons to believe that markets in property rights in spectrum will be better at delivering this desideratum, or whether it would better be served by markets in equipment that does not depend on secured rights to specified bands.

The answer is, fundamentally, that we do not know, but we have very good reasons to think that open wireless networks will be more efficient, all things considered, than networks based on a spectrum property rights approach. Now, this is saying both a lot and a little. It is saying a lot because much of current economic commentary on spectrum policy and the *zeitgeist* at the FCC assumes with certainty that we do know the answer—that is, that property rights in spectrum allocations are the optimal approach to attain wireless communications efficiency. This is false, and to say that the reigning conception of current policy debates is false is saying a lot. It is saying a little, however, because we do not yet have a good enough understanding, either theoretical or practical, of the limits on the scalability, efficiency, and growth rate potential of open wireless networks, and so we cannot be certain that at some point introducing a pricing element tagged to the bandwidth used will not improve on a purely commons-based approach. We can, however, outline a series of considerations that tend to suggest that open wireless networks will be more efficient than wireless systems that must be designed around property rights in bands of frequencies. We can also suggest why even if pricing would sometimes be useful, it will only be useful if designed to provide for peak utilization overload relief rather than as a baseline attribute of all wireless communication.

Ironically, the most important reason to doubt the efficacy of property rights in spectrum is rooted in the work of Ronald Coase, the very economist whose incisive critique of the spectrum-licensing regime gave birth to the economists’ critique of the

old model of spectrum regulation. Coase's Nobel Prize in economics was founded on his introduction of the concept of transaction costs. He explained that using markets to solve problems—like organizing labor and resources into productive combinations, or deciding who among different possible claimants should use a given resource—is a costly exercise. One has to define the rights in resources, collect information about who is doing what, and how much they value things; one has to get parties together to transact, and one has to enforce both rights and agreements. When these costs make market transactions too expensive to solve a resource allocation problem, other mechanisms must do so. Firms and managers who decide which worker uses which raw materials and which machines, and judges deciding who among competing parties should get an entitlement, are instances he used in his two most important articles to show how institutions emerge to allocate resources when markets are too expensive to use for this purpose.²⁷

Like the introduction of friction into Newtonian physics, the introduction of transaction costs into economics changes many predictions about when markets will or will not work. In the case of property theory, in the past decade in particular there has been a burgeoning literature on common pool resources, common property regimes, and commons that has suggested that individually owned property is not always the most efficient way of regulating the use of a resource.²⁸ Whether individual property based resource management or some other arrangement, including even free access and use on a first come, first served basis, is more efficient will depend on the characteristics of the resource and on whether implementing individual property rights will be more costly than the benefits it offers in terms of efficient utilization of the resource.²⁹ To compare the social cost of institutional alternatives of spectrum property rights and open wireless systems, we need to specify the

²⁷ Ronald Coase, *The Nature of the Firm*, 4 *Economica* 386 (1937); *The Problem of Social Cost*, 3 *J. Law & Econ.* 1 (1960).

²⁸ Carol Rose, *The Comedy of the Commons: Custom, Commerce, and Inherently Public Property*, 53 *U. Chi. L. Rev.* 711 (1986); Elinor Ostrom, *GOVERNING THE COMMONS* (1992). Another seminal study was James M. Acheson, *THE LOBSTER GANGS OF MAINE* (1988). A brief intellectual history of the study of common resource pools and common property regimes can be found in Charlotte Hess & Elinor Ostrom, *Artifacts, Facilities, And Content: Information as a Common-Pool Resource*, (paper for the “Conference on the Public Domain,” Duke Law School, Durham, North Carolina, November 9-11, 2001), *forthcoming J. L. & Contemp. Probs.*. In the context of land, Ellickson suggests that there may be a variety of reasons supporting group ownership of larger tracts, including the definition of efficient boundaries (efficient for the resource and its use), coping with significant shocks to the resource pool, risk spreading, and so forth. Robert Ellickson, *Property in Land*, 102 *Yale L.J.* 1315 (1993). The specific sub-category of instances where excessive division of rights leads to stasis has been termed the “anticommons” problem, following Heller. Michael A. Heller, *The Tragedy of the Anticommons: Property in the Transition from Marx to Markets*, 111 *Harv. L. Rev.* 621 (1998)

²⁹ At a broad level, this definition is consistent with the description of the emergence of property rights offered by Harold Demsetz, *Toward a Theory of Property Rights*, 57 *Am. Econ. Rev.* 347-357 (1967).

parameters of the social cost of a wireless communication, and then to identify how these differ in the two regimes.

The social cost of a wireless communication

Let $a\dots n$ represent a network of devices that enables communications at least among some nodes that are part of this network (some, like base stations, may be dedicated solely to facilitating communication among others). This includes open networks, but is general enough to describe even the receiver-transmitter pair involved in a traditional broadcast transmission or a proprietary cellular communications system. The social cost of a wireless communication between any a and b that are part of $a\dots n$ is defined by three components. First, equipment cost of the network of devices that enables a and b to communicate, $E_{a\dots n}$. The equipment cost parameter is intended to be expansive, and to cover all costs including labor and software etc. related to network maintenance necessary to enable the communication. Second, displacement, $\Delta_{a,b}$, where $\Delta_{a,b}$ represents the number of communications between any sender-receiver pair x, y that the communication between a, b displaces, and their value to x, y . Third, overhead O , which refers to transaction and administrative costs. The cost of the communication is, then, $C_{a,b} = E_{a\dots n} + \Delta_{a,b} + O$.

Equipment – At this very early stage of the development of equipment markets that are the precursors of open wireless systems, it is very hard for us to say anything definitive about the total equipment cost of open wireless networks versus spectrum property based networks. We do, however, have reasons to think that the investment patterns will be different in each of the two systems, in the sense that property systems will invest more at the core of the network and have cheaper end user equipment, while open wireless networks will have exactly the opposite capital investment structure.

The end user equipment market is the primary market driving innovation and efficiency in the open wireless network model. Processing gain and cooperation gain increase the capacity of a network, but at a cost of increasing the complexity of the network and the signal processing involved. In a system whose design characteristic is that it is built solely or largely of end user devices, both types of gain are determined by the computational capacity of these edge devices. Equipment manufacturers can provide users with the ability to communicate more information more quickly in an open wireless model through the use of better equipment—with higher computation, better repeating capability, better antennae. But doing so adds cost to the equipment. Even if bandwidth use is free, an equipment manufacturer will design equipment that uses more bandwidth only for so long as the cost in computational complexity of adding processing gain by adding bandwidth is less than

the value users place on the incremental increase in their capacity to communicate. Similarly, the sophistication of the cooperation gain that will be embedded in the equipment will be limited by the cost of the added complexity and the lost capacity, if any, necessary to transmit network information among the cooperating nodes. The cost-benefit tradeoff in open wireless systems is therefore part of the end user equipment cost. It is priced at the point at which the end user decides whether and how much to invest in buying equipment capable of participating in an open wireless network. Users will generally invest in better equipment up to the point where the value of additional capacity gained from the investment will be less than the incrementally higher cost. It is a dynamic we know well from the computer market, and it is a dynamic we are beginning to see in the WiFi market precisely for wireless communications capabilities, as we begin to see a migration from the cheaper 802.11b equipment to more expensive, higher speed 802.11a equipment. The result is that the value of communicating without wires in an open wireless system is capitalized in the end user equipment, and the sophistication and capacity of a network built of such devices is a function of the demand for computationally intensive end user equipment.

In spectrum property based networks, the efficiency of the system arises from pricing communications over time. It is impossible both to capitalize the value of free communications over the lifetime of the equipment into the *ex ante* price of user equipment, and to price usage *ex post* to achieve efficiency. The prospect of paying *ex post* will lead users to invest less in the computational capabilities of the equipment *ex ante*, leaving the network owner to make up the difference in the intelligence of the network as a whole by investing at the core of the network. These investments can both improve the capacity of the network—for example by adding cell towers to intensify reuse of the same frequencies—and implement pricing, such as by adding local market-exchange servers that would allow the network owner to price efficiently on a dynamic, local basis. Whether these investments, financed in expectation of being covered through usage fees, will be higher or lower in total than the investments to be made by users in open wireless network equipment is not, *a priori*, clear.

It is important to see, however, that the efficiency with which a spectrum property based system can price bandwidth is limited by its investment in infrastructure equipment. Demand for communication is highly variable, and, as the following section explains, the displacement effect of any given wireless communication is highly localized.³⁰ In order to price efficiently, a spectrum-property

³⁰ Even in open areas the power of a radio signal fades as a function of the square of the distance, and where there are buildings, trees etc, it fades even more rapidly, typically as a function of distance to the third or fourth power. As signal fades, it contributes less to the “noise floor” that other communications need to contend with. Needless to say, in the traditional model of communications fading is a problem,

based network must dynamically acquire information about the communications needed and the local conditions under which they must be cleared. Doing so requires deployment of many local market exchanges or pricing points that will collect information about who wants to transmit at a given moment and what their displacement effect will be, so as to price communication for that moment for that locale dynamically. A spectrum property owner will only invest in such equipment up to the point where efficiency gains from investing in the necessary equipment outweigh the cost of the added equipment. At that point, the spectrum owner will price based on more global judgments regarding types of competing uses, rather than on dynamically updated information about actual intended usage and actual local displacement effects.

Displacement – The second parameter contributing to the social cost of a communication is its displacement effect—that is, the extent to which the clearance of one communication in its intended time frame displaces the clearance of another in that other communication’s intended time frame. While equipment cost is mostly a fixed cost for any specific communication, displacement represents its primary variable cost. In order to see the effects of processing and cooperation gain on displacement, I derive the definition of the economic displacement effect of a transmission from the definition used in multi-user information theory to define the capacity of a sender-receiver pair to transmit information. First, let us define the displacement effect of a communication between sender-receiver pair a, b , $\Delta_{a,b}$, as $\sum \Delta_{x,y} V_{x,y}$, that is, the sum of communications dropped because of the a, b communication by any other pair, x, y , each multiplied by its value to its senders and receivers. For purposes of this general analysis, I will assume that any given $\Delta_{x,y}$ has a value of either 0 or 1, that is, it either is dropped or it is not. The value of $\Delta_{a,b}$, will be the total number of communications where the transmission from a to b causes $\Delta_{x,y}$ to equal 1, multiplied in each case by the value of the communication to its participants. If we wanted a more fine-grained cost-benefit analysis that includes lost speed, we could further refine this definition by treating incremental declines in information throughput rates as independent cases of displaced communication, and treat $\Delta_{x,y}$ as

because signal power fades just as quickly as the power of interfering devices. Traditional broadcast communications overcome this characteristic of radio signal fading by amplifying their signal so that it reaches many more locales than demand it. By doing so, like a classic smokestack industry, they produce tremendous displacement on all communications that might have taken place in their absence over a large space. UHF stations, for example, whose market value depends largely on cable retransmission, nonetheless radiate at a level that inhibits communications in wide geographic regions, whose reach is defined by the theoretical ability of the least sophisticated receivers to receive a signal in a given radius, irrespective of whether there is any person who owns a receiver actually has a UHF antenna, much less wishes to see the programming but does not subscribe to cable. See Reed, Comments, *supra*.

having some value between 0 and 1 based on the number of incremental decreases in throughput.

Here I adapt a multi-user version of Shanon's theorem³¹ to define the information that is being lost or communicated as the information in the potentially displaced communication, while separating out the marginal contribution of the communications whose displacement effect we are measuring to the total radiation that the potentially displaced communication must deal with in order to achieve effective communication. Let $P_x(t)$ be the transmit power of node x , and $\mathbf{g}_{x,y}(t)$ the channel gain between x and y , such that the received power of the transmission by x at y is $P_x(t)\mathbf{g}_{x,y}(t)$. Let \mathbf{b} be the signal to interference ratio needed by y for communication, and N_0 the level of electromagnetic radiation treated by y as background noise that exists in the channel that x, y , are using independent of the transmission from a to b . Let k represent any node that is part of $a\dots n$, including a and b , that radiates to facilitate the transmission from a to b . $P_k(t)\mathbf{g}_{k,y}(t)$ is the received power at y of the transmission by each k as part of the communication a, b . π represents the processing gain of system $a\dots n$, and α the cooperation gain of that system. The value of π is 1 for a system that has no processing gain, and increases as processing gain increases. The value of α is 0 for a system that uses no cooperation gain, and increases as cooperation gain increases.

$\Delta_{x,y} = 1$ when

and

$$\frac{P_x(t)\mathbf{g}_{x,y}(t)}{N_0} \geq \mathbf{b} \quad \frac{P_x(t)\mathbf{g}_{x,y}(t)}{N_0 + \frac{1}{\pi + \alpha} \sum_k P_k(t)\mathbf{g}_{k,y}(t)} < \mathbf{b}$$

$\Delta_{x,y} = 0$ when

or

$$\frac{P_x(t)\mathbf{g}_{x,y}(t)}{N_0} < \mathbf{b} \quad \frac{P_x(t)\mathbf{g}_{x,y}(t)}{N_0 + \frac{1}{\pi + \alpha} \sum_k P_k(t)\mathbf{g}_{k,y}(t)} \geq \mathbf{b}$$

³¹ In particular I modify here Equation 1 from Grossglauer and Tse, *supra*.

This is a rather complex formulation of the fairly simple intuition that one communication displaces another when *the marginal contribution* of the former to the total radiation perceived as noise by the receiver of the latter leads that receiver to fail to decode the information. The value of this formulation, nonetheless, is that it separates out the marginal contribution of the communications system involved in transmitting the potentially interfering communication, expresses the effect of processing gain and cooperation gain in determining that marginal contribution, and underscores the externalities imposed by the sensitivity of the displaced communication, expressed by \mathbf{b} , in contributing to the perceived social cost of the potentially displacing communication.

Three types of effect on processing gain, cooperation gain, and the signal to interference ratio of devices that might be displaced, \mathbf{b} , suggest that the total number of displaced communications is likely to be smaller for communications in open wireless networks than for communications in a spectrum property-based system. First, π increases with bandwidth. A property system that prices bandwidth will, all things being equal, induce lower usage of bandwidth than a system that does not price bandwidth—that is, after all, precisely its purpose. Transaction costs associated with pricing over time contribute further to reducing the bandwidth used. Any wireless communications system that uses less bandwidth than it is computationally capable of using will be able to attain less processing gain than its potential, and hence will displace more communications than it could if it were to use as much bandwidth as it was computationally capable of using in order to attain processing gain.

Second, π and α are a function of the computational ability of the edges of the network—the receivers and the transmitters. Processing gain and cooperation gain increase with computational intensity. As explained in the discussion of equipment investments, the capital investment structure of spectrum property-based systems will generally reduce the computational capacity at the edges, in particular user equipment, be it transmitter or receiver. This is because a property system with a network operator will migrate value into the network as the basis for long term pricing of communications, rather than building all the long-term value of communication into end-user equipment. Assuming that computational capability is the primary source of equipment cost, a system that wants to price usage over time rather than capitalizing the value of free usage over time into the cost of the user equipment will build less computationally intensive user equipment and replace computation at the edges, which is not usage priced, with power and computation in the network, which is susceptible to usage-based pricing. If this in fact describes the likely equipment investment structure of spectrum property systems as a direct consequence that their

claim to efficiency requires that they price over time based on usage, then a spectrum property based network will have simpler equipment at its edges, total demand for communications with either system being equal. It will therefore have lower processing and cooperation gain than open wireless networks, unless the spectrum owner invests enough in intelligent network components very close to the end users so as effectively to replicate the spatial diversity and receiver processing capabilities of open wireless networks. That, however, would roughly require replication of the entire investment that an open wireless network would make within the owned infrastructure, and would still require in addition end user equipment and devices intended to price usage. Again, this suggests that an open wireless network will likely displace fewer communications than a spectrum-property based system.

Third, for any receiver, a low \mathbf{b} is a positive externality, in that it makes that receiver more impervious to the effects of other transmissions. Communications between any a, b pair near an x, y pair are less likely to displace x, y when y has a low \mathbf{b} . The a, b communications therefore impose less social cost than they would have had they displaced x, y , but the benefit of communications between a, b made possible by this lower cost are captured by a, b , not by y . Making a receiver more resistant to interference, however, imposes a cost on y . Conversely, all things being equal, having a higher \mathbf{b} makes y 's receiver cheaper, but causes more communications a, b , to displace it, thereby making the a, b communication appear to have a higher social cost measured in $\Delta_{x,y}$. A high \mathbf{b} is therefore a negative externality. Like Coase's famous vibration-sensitive physician, a cheap receiver as much "interferes" with the transmissions of its neighbors as these neighbors "interfere" with the cheap receiver's reception.³² Receivers designed to be part of open wireless networks need a low \mathbf{b} in order to communicate, since they are designed to operate in the presence of many other transceivers sharing the same bandwidth. Each receiver therefore sees at least some of the benefit of the low \mathbf{b} as a private gain, and the benefit increases proportionately with the expense of making the receiver require ever-lower signal-to-interference ratios. Receivers designed to be part of spectrum property based systems, on the other hand, will be cheaper and have higher \mathbf{b} values. Receivers in such systems need not have a low \mathbf{b} because the purpose of the property system is to allow them to be reached by transmitters who need not share the channel with anyone else. The \mathbf{b} rate is pure externality to a receiver in a system of property in transmission rights.³³

³² See *infra*, pages 33-34.

³³ Indeed, it was precisely the need to provide for the growing market of relatively cheap receiver sets that drove the development of the radio industry in the 1920s and formed the basis of the band-licensing model that has been with us ever since. See Benkler, *Overcoming Agoraphobia*, *supra*.

Because of these three factors, any a, b , communication cleared through a spectrum property system is likely to have lower values for π and α , and any x, y communication in such a system will likely have higher values for b . If all devices are part of a spectrum property based system, a given a, b communication will cause the largest number of communications to be displaced. In a system where a, b are part of an open wireless network and x, y are not, a, b will have a lower displacement effect. The lowest displacement will occur if all devices involved are part of open wireless networks. If the property system is to be more efficient than the open wireless system, then, it must gain its efficiency from the $V_{x,y}$ element of the displacement parameter. That is, the contribution to the social cost of a property system represented by its displacement factor, $\Sigma\Delta_{x,y}V_{x,y}$, will be lower than the displacement factor of an open network only if the value differential between those communications that each system drops is sufficiently high in favor of the pricing system that it overcomes the higher volume of displacement likely to be caused by the spectrum property based system.

Now, we can easily see that this formulation includes the edge case that all sides to the spectrum policy debate agree on—that is, that where an open networks' capacity will be greater than demand, there is no scarcity and the property system imposes a social cost without providing any benefit. That is, whenever $\Sigma\Delta_{x,y} = 0$ because the open system has succeeded in increasing capacity faster than demand, then the insensitivity of the open wireless networks to the individual value of the displaced communications will not cause the spectrum property based system to yield better results. Similarly, but less definitively, when the volume of displacement is very small, pricing will improve performance only if the communications that happen to be dropped by the value-insensitive protocol of the open wireless network have an unusually high value.³⁴

More generally, it is likely that there will be some range where the total value of the displacement factor for open networks will be smaller than the displacement value of a spectrum property system, and this range will grow as a function of computation, the amount of bandwidth that open systems are permitted to use, and the pricing inefficiencies in spectrum property based networks. The speed of computation growth is given by the innovation rate in the computation markets. Moore's Law has been a reasonable predictor of this for quite a while. The extent to which this growth can be utilized to improve the efficiency of open wireless networks is partly limited

³⁴ This is presumably why Hazlett describes the demerits of the Internet's lack of pricing, by analogy to open spectrum, in caricature-like terms rather than with practical and common examples. See Hazlett, *Wireless Craze*, at [136-7 of Brookings-AEI version] (“Classically, the brain surgeon cannot read the life-and-death CT scan because the Internet's backbone is clogged with junk e-mail.”)

by the total bandwidth that regulation permits equipment manufacturers to use for achieving processing gain.

Overhead: transaction costs and administrative costs – The most important transaction costs associated with open wireless networks are expressed as the network management overhead that devices need to use in order to coordinate their communications. The most important transaction costs associated with spectrum property based markets are those entailed by the need to negotiate clearance of permissions to transmit in a specified bandwidth.³⁵ The primary administrative costs of the property system are the definition and judicial enforcement of the property rights. The primary administrative costs of the open wireless system are the standards setting processes and the administrative enforcement of equipment compliance with them.

The first part of this section explains why the transaction costs associated with market clearance of property rights will be systematically higher than the transaction costs associated with open wireless network communications. In the alternative, their avoidance by the property system will lead to systematic and inefficient overpricing of “spectrum.” The inefficiency stems from the comparative stickiness of the spectrum property framework in its ability to adapt dynamically to changing local conditions and demand. The second part of the section explains why the administrative costs of open wireless systems are likely to be lower.

There are two primary reasons for the central importance of dynamic adaptation to the efficiency of wireless communications systems. First, wireless communications capacity is mostly determined by local conditions, such as who is trying to communicate in a relatively small geographic space, or whether there are leafy trees between two nodes, and which way they are swaying, etc. Second, human communications are highly variable, even over large-scale networks and time frames, and certainly where the relevant demand exists in geographically small areas and for brief time frames.³⁶ The capacity of a system will be heavily dependent on whether it

³⁵ Since each system requires that users have equipment with which to communicate, the transaction costs associated with equipment purchases largely cancel out, except that, on the one hand, the property system will likely require more transactions for equipment in the core of the network, while open wireless networks may have higher installation costs for end user equipment because of the relative complexity of the end user devices. These, however, could largely be treated as part of the higher ex ante equipment cost associated with open wireless networks.

³⁶ Because of fading and the fact that “spectrum” is perfectly renewable from one moment to the next, the relevant locale and time frame for gauging demand and displacement are geographically proximate and temporally dynamic, and with packet based communications, the relevant time frame is on the order of milliseconds.

can design its wireless communications network dynamically to take advantage of changing conditions, or whether it adapts more slowly. To the extent that dynamic adaptation is important, open wireless networks are likely to outperform networks that rely on proprietary spectrum, because the dynamic adaptability of the latter is more limited by transaction costs.

As I explained in the technical description, open wireless approaches rely on intelligent devices that constantly reconfigure the network architecture, the power used, and the frequency bands used—both in terms of total bandwidth used and in terms of specific frequencies used—to fit the dynamically changing environment and usage patterns. Property rights and pricing mechanisms that are attached to spectrum allocations—that is, to a particular band of frequencies—burden this dynamic adaptation of wireless networks by making the bandwidth parameter “sticky.” That is, bandwidth is one parameter that, unlike computation, architecture, and power, cannot be changed unilaterally and locally by the network of intelligent devices. It requires a transaction. A shift to a different range of frequencies or a different bandwidth entails identifying who the owner is, finding the lowest cost frequency set that would fulfill the needs of the system at that moment, negotiating a transaction, and shifting to the new spectrum for the specified time slot.

To illustrate the problem, imagine a perfectly functioning, automated market exchange point where all proprietors of bandwidth are present to vend their wares, ignoring for the moment difficulties with multiple property holders whose systems do not intersect, and ignoring that network equipment costs will limit how much a spectrum property owner will be willing to invest in equipment intended to gather information so as to price efficiently. The optimal transmission path and architecture for any given sender-receiver pair in a network of transceivers is highly local and dynamic. This is particularly so when mobile units are considered. For example, Figures 7, 8, and 9 describe three different potential states that a specific sender receiver pair a, b might be in, depending on the presence or absence of, say, trees and additional nodes available for repeating or collaborative detection. In each case M represents the market exchange point, x, y represent a sender receiver pair whose displaced communication, if any, represents the social cost of permitting a and b to communicate as they had intended. I assume for simplicity that there is some mechanism for a, b to communicate to M that is fixed and does not itself require a

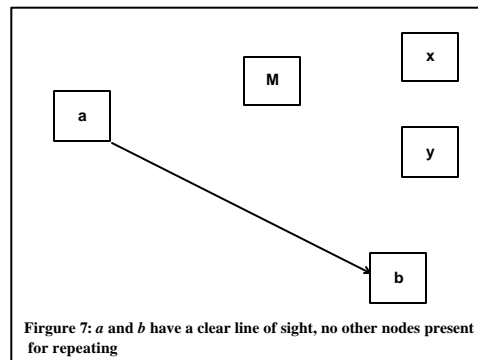

negotiation of spectrum rights. In Figure 7, a, b is a lonely pair, with no repeating nodes available to cooperate, and with no obstacles to block line of sight. Under these conditions the pair could transmit a given number of bits per second using either high or low frequency spectrum, using a little bit of bandwidth, say, 6MHz, at high power, or a larger amount of bandwidth, say 300MHz, which would give them sufficient processing gain to transmit at such low power that no other sender-receiver pair in the area affected by their radiation would be displaced. In other words, given the signal to interference ratio necessary for the pair x, y to communicate, and the distance from a, b to x, y , a transmission in a, b spread over 300MHz will not affect the ability of x, y to communicate. In terms of the formal representation of the displacement parameter, if the signal is spread over 300MHz then $\Delta_{x,y} = 0$, but if it spread over, say, anything less than 50MHz, $\Delta_{x,y} = 1$, while if it is spread between 100-250MHz, $0 < \Delta_{x,y} < 1$. Imagine that all the frequencies are divided into 20MHz to 50MHz blocks. This is a reasonable assumption given that the cost of attaining processing gain is tied to computation and the price of computation drops rapidly over time. We can therefore safely assume that at any given time user equipment will be computationally capable of using more processing gain than it could have used in the past. Hence, even assuming that past aggregations of bandwidth that permitted open wireless operation had a width sufficient to take advantage of all the computation then available, whatever that efficient bandwidth was in the past it will be less than what current computation makes possible at reasonable consumer prices. a, b , are computationally capable of using 300MHz, but can only communicate over 300MHz if they can get transmission rights from at least six owners, each of whom owns at least 50MHz of bandwidth. As we defined the effect of processing gain achieved by spreading over 300 MHz, the correct price of the transmission right necessary to spread the signal over 300MHz is zero, since spreading the signal to that width will reduce the marginal social cost of the bandwidth used by the communication—its displacement effect—to zero. Yet no single owner would be willing to sell transmission rights over its spectrum for that amount, given nonzero transaction costs associated with fixing the correct price, as well the cost of communications that would be displaced if the signal is spread only to 50MHz, rather than 300MHz, which is all the spectrum owner can secure and monitor unilaterally. All parties would have to negotiate simultaneously as to whether a, b would spread to 100, 200, or 300 MHz given cumulative transaction costs of deciding which power/bandwidth combination would be less expensive to combine, given the resulting effect, if any, on any pair x, y . Note that, knowing that they will encounter such transaction cost constraints on their ability to pursue feasible non-displacing communications, a and b will both under-invest in high-computation equipment in the amount of lost potential communications over the lifetime of the equipment that they will not be able to achieve because of transaction costs.

Open wireless networks, however, also have transaction costs, specifically the overhead traffic necessary to identify the most efficient transmission path. If high

enough, these will also constrain efficient communication under that approach. While true, it is important to understand that these are transaction costs that *both* open wireless systems and proprietary spectrum systems must incur, if pricing in the latter is to be efficient. Take, for example, a similar situation to the one in Figure 7, but because *a* and *b* are mobile units, geography and network topology between them change. In Figure 8, a tree has intervened between them and one more potentially cooperating node has appeared as well. Now *a* and *b* need lower frequency spectrum (which can go through leaves) if they are to communicate directly, but can use higher frequency spectrum with direct line of sight if they use *d* as a repeater. In Figure 9, not only has a tree appeared, but so have some buildings, and additional nodes *e* and *f* situated behind a set of buildings whose multi-path effects would let the smart antennas of *e* and *f*

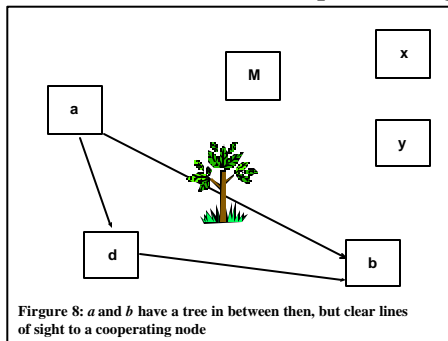

achieve multi-user detection in cooperation with *b*. *a* and *b* have to compute which of several strategies would result in the lowest error rate at the minimal power at a desired speed: relying on nodes *e* and *f* as a distributed antenna array for *b*, on *d* and *f* as repeaters for *b* (perhaps alternating high frequency for the first and last hops from *a* to *d* and from *f* to *b*, and low frequency from *d* to *f*), or on direct communication at a low frequency.

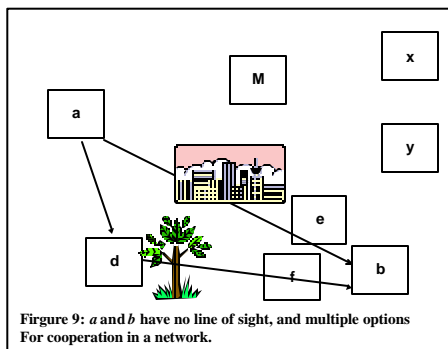

*Without computing all these potential courses of action, it is impossible to tell what effect the desired communication from *a* to *b* would have on any given sender receiver pair *x*, *y*. Because the effect on *x*, *y* represents the marginal social cost of the *a*, *b* communication, it is impossible efficiently to price the bandwidth *a* and *b* need before *a* and *b* have all the information they need in order to determine what is the lowest possible displacement they could cause other communications. A spectrum market has higher transaction costs for achieving efficiently priced communications than an open wireless network has for efficient communication at least to the extent of the positive transaction costs incurred after *a*, *b* communicate to the exchange the range of possible communication patterns open to them. The point here is not that*

property rights burden open wireless networks, as they surely do and as I will discuss in the next few paragraphs. The point is that *any* potential communication from any *a* to any *b*, whether done in an open wireless network or in a proprietary system, will need to map its least displacing configuration, given available network topology and deployed equipment at any given time *t*, as a precondition to efficient pricing. “Spectrum” at that time and place cannot be priced efficiently in the absence of this information, for this is the information that defines the marginal cost of any communication over any wireless network. To the extent that a spectrum property based system cuts its transaction costs by pricing spectrum on less refined information, to that same extent it is pricing inefficiently.

In the most technologically sophisticated version of the property rights argument, Faulhaber and Farber recognize the fact that transaction costs (which they call direct)³⁷ of a spectrum property system are higher than the transaction costs of an open wireless approach, or a spectrum commons.³⁸ Indeed, it is to solve this problem that they propose a modified property system, rather than one based on perfect rights of exclusion. Their preferred regime implies into all property rights in spectrum a public “easement” that permits anyone, anywhere, to transmit at any frequency as long as they do not interfere with the owner of the right to transmit in that frequency. This modified property regime is intended to permit very wide band communications that are “below the noise floor” given the operating parameters of the devices that operate with the property owner’s permission in the frequencies they utilize, as well as agile radios that occupy frequencies only when their owner is not using them, and as soon as the owner wants to transmit, hop to a different, unused frequency. While Faulhaber and Farber agree that direct transaction costs are likely to be higher in either property-based approach than in a commons-based approach, they do not attempt to specify the effect of these transaction costs. It is important to emphasize that these transaction costs go precisely to limit the capacity of the spectrum property system to do the one thing that potentially could make it more efficient than open wireless networks—that is, accurately to identify competing values that users place on communications, and to adjust the price of bandwidth accordingly. The important measure of the transaction costs is the extent of the deviation they cause from efficient pricing in the spectrum property based system. The more that transaction costs cause the spectrum property system to utilize prices that reflect statistical judgments about competing usage patterns, rather than actual real-time bids, the less of a value there is in these systems as compared to an open wireless system that treats all

³⁷ Faulhaber and Farber use the term “direct transaction costs” to describe what I describe here as transaction costs, and “indirect transaction costs” to describe what I call here “administrative costs.”

³⁸ Faulhaber & Farber, 16-19.

communications equally and will drop high and low value communications with equal probability, but will drop fewer communications in total.

Faulhaber and Farber are also quite cognizant not only of the internal limits that the transaction costs associated with spectrum property rights impose on that system's own efficiency, but also of the externalities that implementing such a system would cause, in terms of the constraints it would place on the technological evolution of efficient open wireless networks. Recall, the problem is that the number of rights holders that a transmitter-receiver pair must negotiate with in order to pull together the right to transmit in a band say, 10GHz wide, is so great that as a practical matter that mode of communication will be unavailable under a pure spectrum property rights approach. They recognize this as a problem akin to what has come to be known as the "anticommons" problem,³⁹ that is, a particularly virulent version of the Coasian problem of inefficient design or allocation of rights in the presence of high transaction costs. It is a condition where rights are so fragmented relative to the efficient contours of a usable resource that the transaction costs of assembling a usable resource out of these fragments are too high to permit it to occur, causing stasis. Faulhaber and Farber offer two types of solutions to this problem. First, they claim that because of the easement they postulate in their modified property regime, that is, the right of anyone to transmit in any frequency as long as they are not interfering with the licensed user/owner, anyone will be able to transmit the 10GHz wide signal as long as they are "below the noise floor." Second, to the extent that communications that would interfere with other devices are desired, they should be permitted in bands purchased for this purpose by the Federal or even state or local governments, or perhaps by manufacturers of open wireless network equipment, seeking to make the market in their equipment more attractive to consumers.

While their modified system is much better than the pure property system, it is still substantially constraining to open wireless network design, and again it is Coase who helps us understand why. In both his *Federal Communications Commission* piece and in the Nobel-winning article he wrote the following year, *The Problem of Social Cost*, Coase introduces the problem of the physician and the confectioner who are neighbors. The confectioner's equipment makes vibrations that make it difficult for the physician to see patients. Normal legal thinking at the time would treat the confectioner as "causing" damage to the physician by making noise and vibrations. One of Coase's great insights in that article was that the physician is "causing" the damage to the confectioner by being so sensitive, just as much as the opposite is true. Who should be shut down or made to pay cannot therefore be decided on the basis of stating who is "causing harm," but should rather be based on

³⁹ Heller, *supra*.

whose activity is more socially valuable. The lesson is directly applicable to the proposition that open wireless networks need not be adversely affected by an exhaustive Big Bang auction of property rights as long as they are permitted to operate without interfering with rights owned under that regime. If, however, we define the operating parameters of open wireless networks based on the sensitivities of the property-based services, we have effectively treated the property-based system as the physician, and the wide band devices and agile radios as the confectioner. But saying that we will allow confectioners so long as their equipment does not vibrate is not to say that we now allow both physicians and confectioners. It is to say that we have chosen to make the world safe for physicians and constrained for confectioners. This may be the right decision or the wrong decision from a social welfare perspective, but it is a decision in favor of one approach, not an accommodation of both.

To be less metaphoric and more specific let me be clear about the effect of high-powered property-based services in a frequency band on open wireless systems. The level of non-cooperating radiation in any given band affects the extent to which a system needs processing and cooperation gain to achieve a certain rate of information delivery through an open wireless network. The more radiation there is, the greater the complexity of the solution to the problem of communicating information through the channel. The greater the complexity of a system, the greater the cost of the equipment needed to implement it. So, holding all other things equal, if you permit *only* open wireless systems to operate in a given range of frequencies, they will be able to achieve a given throughput at lower cost than they could if they need to achieve the same throughput in the presence of high powered communications. So, while the modified property right is much better than the perfect property rights regime in that it does not completely prohibit open wireless systems, it still imposes a burden on the development of those systems. Perhaps the proponents of spectrum property rights are correct, and that burden is socially justified given the relative value of both types of approaches—the proprietary and the open—to wireless communications. But the modified property right does not allow us to eat our cake and have it too. We must still choose how much we will have of each type of wireless communications facility.

As for the suggestion that the Federal or state or local government bodies will buy spectrum to create parks, this is a surprisingly naïve proposal from two such sophisticated authors. If one were to think that Congress and the federal government were rational decision makers who operate to optimize the public good with the same efficiency as, say, any large corporation maximizes the benefits to its shareholders, this might not fundamentally be a mistaken approach. But the notion that Congress is equally likely to appropriate \$x already in the Treasury as it is to forgo potential

revenue by refraining from auctioning the spectrum, particularly under the politically palatable heading of reserving it for a public trust, is surprising. As a matter of treating the government as a rational agent responding to real costs, forgoing x millions of dollars by refraining from auctioning the spectrum is identical to spending that amount of money after the spectrum is sold. As a matter of practical politics, they are not similar in the least. I suspect that the reason for this aspect of the Faulhaber and Farber proposal has more to do with the integrity of the transition policy—that is, with the big bang auction that is intended to launch the property system. But this is a transition policy that would result in substantially lower public investment in space for open wireless networks than might a differently framed public debate, and the transition policy should not be allowed to preempt the outcome of such a controversial policy question.

As for administrative costs, or what Faulhaber and Farber call indirect transaction costs, they suggest that the open wireless approach has the highest indirect costs, because uncertainty as to what equipment is “interfering” or complying with the open protocols and what is not will be confusing and difficult, and hence costly, for courts to sort out, and will lead to much litigation. They claim that the pure property regime will have the lowest indirect costs, because courts are most adept at solving property rights disputes. And they see their own preferred modified property regime as having higher administrative costs than pure property, because the boundary between the easement and the property rights will lead to difficult litigation, but lower than the administrative costs of open systems, because courts, familiar with property disputes, will find a property framework easier to design and enforce than an open system.

This view of the administrative costs takes a somewhat more rosy view of property litigation, and a more dim view of administrative equipment certification and private standard setting, than I would. All one need do is look at the decades-long history of some of the cases that I teach every year in my first year property course to see that courts do indeed resolve property disputes, but to say that they will do so efficiently because of their experience with real property is somewhat optimistic. It is important in this regard to see that disputes about use of open wireless networks will occur not with regard to property-type claims, but with regard to equipment compliance with standards. Here, standards can be set for whole industries by open processes like the IEEE or W3C standard setting processes. The FCC can then certify equipment as it does now on a Part 15 model. In all these cases, the administrative costs are incurred, but once incurred apply industry wide, and can be enforced against non-complying equipment fairly simply by engineering tests of the equipment. This is by no means a costless exercise for dispute resolution, but it is vastly cheaper and more certain than relying, say, on the owner of property rights in 724-744MHz in Des

Moines, Iowa, to sue the owner of 745-747MHz in one neighborhood there for using a particular antenna configuration, with the owners of 748-768MHz and 712-23MHz as third party intervenors, and then on courts of appeal to resolve conflicts between how the Iowa court and another court, say adjudicating similar claims in the 2GHz band in Memphis Tennessee, decided the case by applying the *sic utere tuo ut alienum non laedat* maxim rather than *damnum absque injuria*.

More generally, others who have written in favor of property rights in spectrum have treated “property” as being anti-regulation, and commons as being regulation by the back door.⁴⁰ The dichotomy between the two in this regard is, however, overstated. In order to have efficient property rights, it is necessary to define, enforce, and update the definition of the content of property rights.⁴¹ These are all functions that require thoughtful institutional design, initially through Congress, later through enforcement agencies or courts. None of this is new or surprising to anyone who teaches a first year property course, and must take the students through the centuries of choices made by judges and legislatures between barons and King, modernizing landowners and their overbearing dead ancestors, or developers and the neighbors who wanted a quiet residential community, not a gas station next door. Lacking the benefit of centuries of gradual development, property rights in spectrum are unlikely to involve less explicit regulatory choices, and Faulhaber & Farber correctly identify the need for well designed governmental planning in the initial creation of the property rights and well functioning dispute resolution to fine tune the rights when reality teaches us the limitations of the original design.⁴² Similarly, in order to have efficient commons, some set of rules about usage may well be necessary. Property rights can be defined or interpreted in an inefficient and corrupt manner, as can a commons oriented regulatory processes. The trick in setting up either arrangement will be to make sure that they are designed so as not to allow the recreation of command and control regulation through the backdoor. In the case of commons, the way to do this is by improving the Part 15 model of equipment certification, so that any sharing protocol and design that is approved by an open

⁴⁰ Hazlett, *Wireless Craze*, *supra*.

⁴¹ See, e.g., DeVany *et al*, *supra*.

⁴² Faulhaber & Farber 7-8 (“In the case of spectrum, spillovers in the form of out-of-band power in adjacent frequencies are important, and can generally be controlled by the careful definition of property rights. In today’s regime, spectrum licensees operate under a set of technical restrictions regarding power and place of emission, and possibly direction and time of emission. In a property rights regime, these restrictions would be codified in the property rights of the frequency owner, who would then be subject to civil penalties should he or she violate these restrictions. In fact, such restrictions are often codified in property rights and laws. My right to use my automobile is restricted by speed limits; my right to use my real property is restricted by noise and nuisance statutes of my state, county and local municipality. Property rights in spectrum would be similarly constrained, and in fact we already know what the constraints are: they are largely defined by the technical restrictions in current licenses.”)

standard setting process gets fast track approval, and these can provide reasonably well known benchmarks against which to measure proprietary standards that seek certification.

Pricing, Block Allocations, QoS, and the Big Bang

The transaction costs analysis suggests three additional observations with regard to the policy implications of the potential value of pricing. Recall that the efficiency with which open wireless networks can provide wireless communications capacity does not necessarily mean that there will never be situations where pricing of bandwidth can improve the efficiency of communication. It is possible that when demand exceeds capacity of a given network of devices, as deployed in a given locale at a given time, introducing pricing will improve allocation of whatever capacity is attainable by the network of devices in place. Three points need to be made with regard to this observation, however. First, the introduction of pricing does not itself support the creation of property rights in blocks of spectrum, as compared to a single fluid market exchange in spectrum on the model proposed by Eli Noam.⁴³ Second, even if some quality of service (QoS) assurance is attainable through the introduction of pricing, that still does not mean that the game is worth the candle—that is, that the cost and implications of introducing a pricing system for assuring QoS is worth the social cost of setting up the pricing system. The experience of wired networks suggests otherwise. Whether it is or is not is a question that can only be determined empirically over time, as we get better information about wireless network usage and capacity given the presence of open wireless networks. Third, whatever the possible merits of pricing, they do not merit, based on our present knowledge, a “big bang” auction of all spectrum, but at most the dedication of some bands to provide pricing to handle peak utilization periods.

First, the dynamic, local, and highly variable nature of demand for wireless communication suggests that block allocation will be systematically inefficient. Similar to demand for electric power distribution, designing capacity to meet highly variable demand will be more efficient if demand can be averaged over all users throughout the year rather than if it is averaged among the contingent distributions of customers of different firms.⁴⁴ One does not want transaction costs involved in shifting users from, say, 724-726 MHz to 964-966MHz to be higher than shifting those same users to 728-730MHz, as they might be if there is one owner for 720-

⁴³ Noam 1998, *supra*.

⁴⁴ In the context of wired networks, the benefits of aggregating users to lower the cost of provisioning for bursty peak utilization and its relationship to industry structure is discussed in David Clark, William Lehr, and Ian Liu, *Provisioning for Bursty Internet Traffic: Implications for Industry and Internet Structure* MIT ITC Workshop on Internet Quality of Service. (Nov. 1999).

730MHz and a different one for 960-980MHz. If transaction costs are higher in this way, then there will be situations where a communication would have cleared given over-utilization of the 720-730MHz band but under-utilization of the 960-980MHz band had these bands been part of a single transactional unit, but will not clear because these bands are separated into two transactional units. This inefficiency of block allocation is central to the efficiencies of the Noam-style market, where all spectrum is available all the time for both spot-market and forward contract purchases, so that the local and dynamic variability in demand can be averaged over the entire usable spectrum as opposed to over smaller ranges of bands. To the extent that the presence of rights in discrete blocks of spectrum add stickiness to the efficiency of the market clearance of bandwidth, to that same extent rights in blocks of spectrum will be less efficient than a single dynamic market in all usable frequencies.

Second, the case of demand occasionally exceeding capacity in a system that throughout many moments has an excess of capacity is very similar to the problems of quality of service presented by wired networks, and for which well thought out models of pricing bits have been proposed.⁴⁵ Pricing-based QoS solutions in wired networks have not, however, been adopted, and there are some reasons to think that they are unnecessary in the foreseeable future for wireless networks. Partly this is due to the fact that computation, storage and caching capabilities have grown so quickly that adding capacity to more than meet demand has been a more efficient solution in the wired world than accepting that capacity cannot meet demand and allocating slow-growing capacity to meet it. In wireless, it is likely that the declining price of computation and the growing market in wireless communications devices will, for any useful time horizon (say, 20 years), make it cheaper to increase supply by improving the end user devices than to introduce a pricing system to allocate slower growing capacity. There is perhaps a more systematic problem with pricing bandwidth as a means of assuring QoS. At all times when demand is not high, pricing the allocation of spectrum introduces a pure transaction cost of maintaining a system that will be available to clear excess demand in those more rare events when demand exceeds capacity. It is only in those peak moments that pricing could in principle improve the efficiency of communications. The aggregate cost-benefit analysis of any pricing system must compute the total transaction costs attached to all communications, relative to the benefit attained in the moments where demand exceeds capacity. While there is no *a priori* reason to think that pricing will not be beneficial, whether or not it

⁴⁵ An economists' version of this proposal is Jefferey Jackie Mason and Hal Varian, *Economic FAQs About the Internet*, 8 J. Econ. Persp. 75 (1994). For a technologist's view see S. Shenker, D. Clark, D. Estrin, S. Herzog, Pricing in computer networks: reshaping the research agenda, 20(3) Telecomm. Policy (1996)

will in fact be beneficial would largely depend on traffic patterns in a system whose characteristics may change dramatically over the time between now and when capacity will begin to grow slowly enough to justify pricing.

Finally, while it is possible that some pricing of spectrum will improve efficiency of some systems sometimes, that possibility does not support a “big bang auction” to create property in all spectrum, always, everywhere, now. In public highways, for example, it is likely that creating a pricing system by using toll roads or paid carpool lanes⁴⁶ in specific locations with predictable congestion patterns will improve efficient traffic flows. This may indeed recommend introduction of pricing in some predictably congestion-prone roads. But it would be odd to derive from that likely geographically and temporally focused improvement that we would be better off introducing property rights, toll-booths, and electronic payment systems for use in all city streets and sidewalks, dirt roads, or highways at nighttime, on the off chance that sometimes these too may become congested and pricing could then be useful to help improve their efficient utilization. It is, in other words, possible that benefits could be attained by allowing some “spectrum” to be treated as a reservoir of bands usable for pricing to serve QoS needs. But that is no basis to have a big bang auction of all usable frequencies, nationwide, before we know how the market in open wireless network equipment develops, and before we know how much spectrum, if at all, could usefully be priced, sometimes, in some locales. At most, the theoretical value of pricing suggests that it would be plausible to adopt a policy of increasing the flexibility permitted to current licensees to use their presently owned bands for resale when utilization is low, or perhaps for dedicating some bands to be run on the Noam pricing model.

Capacity, Growth, and Efficiency: Conclusion

The economic comparison between the efficiencies of property rights in spectrum allocations and those of open wireless networks can be restated in the following main points:

- The choice is between a market in infrastructure rights and a market in equipment, not between a market approach and a non-market approach
- Evaluating the social cost of a communication in either system requires evaluating the equipment cost involved in enabling the communication, the displacement effect a cleared communication has on other communications

⁴⁶ Lior J. Strahilevitz, How Changes in Property Regimes Influence Social Norms: Commodifying California’s Carpool Lanes, 75 *Indiana L. Rev.* 1232 (2000).

that are not cleared because of it, and the overhead involved in clearing the communication in terms of transaction costs and administrative costs.

- It is difficult to predict the total cost of equipment necessary for spectrum-property based communications relative to the cost of open wireless network equipment. It is likely that investment in a spectrum property model will be more centralized at the core of the network, with cheaper end user devices, and investment in an open wireless model will be more decentralized and located in the hands of users, representing a capitalization of the value of communications over the useful lifetime of the equipment either in the hands of the network owner (with spectrum property) or in the hands of users, in the absence of a network owner.
- Open wireless systems are likely to be able to grow capacity more rapidly than spectrum property based systems, because the free availability of bandwidth and the higher computational intensity of end user equipment will allow such systems to use and improve processing and cooperation gain in pace with the price/power growth in processing, while property based systems will be limited by the lower computational complexity of end user devices, the relative stickiness of proprietary bandwidth, and the likely higher signal-to-noise ratio required by receivers.
- The relative advantage of pricing bandwidth will occur, if at all, only at peak utilization moments, and is akin to pricing based QoS approaches in wired networks. Attaining that advantage may not be worth investing in deploying these approaches at all, as it has not in the unregulated world of wired networks.
- Transaction and administrative costs of markets in spectrum are likely to be higher than those associated with communications in open wireless networks
 - Direct transaction costs will limit the ability of spectrum property based systems to price efficiently
 - Given that spectrum property based systems grow capacity more slowly than open wireless systems, the limitations on their capacity to price efficiently may be fatal to their justifiability
 - Administrative costs of litigation in a property system are likely to be higher than the administrative costs of equipment certification processes, at least if the latter are designed to be no more burdensome than current equipment certification programs, and particularly if those are streamlined for standards set in open private standard setting processes.

V. INNOVATION, WELFARE, AND SECURITY

In addition to the fundamental point about the limitations of property in spectrum allocations as mechanisms for optimizing the capacity of users to communicate without wires, there are other, more general points to make regarding the likely advantages and limitations of open wireless systems. These fall into the categories of innovation, welfare enhancement, and security.

Innovation – In addition to reasons we have to think that property in spectrum will not improve capacity utilization over time, we have reasons to believe that an open wireless system will have better characteristics where innovation is concerned. The property-in-spectrum model relies on the owners of spectrum to innovate in order to increase the value of their spectrum. The open wireless approach, on the other hand, relies on the openness of the system and on the notion that the smartest people usually work for someone else. That is, the principle of innovation underlying the Internet, as Lessig described so forcefully in *The Future of Ideas*, is the idea that the network itself is simple and open. Everyone then gets to innovate as they wish, and can use the network as long as they can translate their new applications into simple modules that can be transmitted using TCP/IP, the open protocol underlying Internet communication. This is fundamentally different from innovation in the Bell System—an immensely innovative company in its own right—where innovation occurs primarily in Bell Labs, because only they have permission to implement. Innovations from the outside are permitted if and only if they fit the Bell revenue model. In wireless systems design too, owners of spectrum are likely to invest in innovation so as to increase the value of “their” spectrum. But they will likely prevent the implementation of innovative communications technology by most outsiders unless it fits their revenue model and they can appropriate it. With a commons approach towards spectrum, however, anyone can innovate. Anyone can develop a device, and if it works better, users will adopt it. Anyone can set up an Internet service, anywhere, and if it offers better service—faster or more robust, cleaner of commercial advertising or better at delivering targeted advertising—that person can offer the service without asking permission of an “owner” of the system, as one would need today for cable or licensed wireless Internet access. This freedom to innovate and implement has proven enormously important to growth and innovation in the space of computers and the Internet. Adopting an open spectrum policy would structure the environment for innovation in the wireless communications systems design along the same lines, rather than on the old, centralized innovation model.

It is important to note that the end-to-end model of open innovation versus the controlled innovation model, where the owner of the space in which innovation is to occur manages innovation, is related to the neo-Schumpeterian concern with market structure and innovation.⁴⁷ The neo-Schumpeterian school of innovation economics focuses on market structure, and suggests that some combination of large and small firms—ranging from monopoly to a market with mixed types of firms with more or less market power and subject to closer or less robust competition—is the optimal market structure for innovation.⁴⁸ The thing to see is that one can have different market structures within the space of spectrum owners and different structures in the market for equipment. In either event market structure in each type of will be more or less optimal from the perspective of innovation effects. The point of innovation in open networks is that whoever is driven to innovate—entrants trying to topple incumbents, or incumbents trying to break away from entrants—is permitted to implement their innovations in the open system, and their innovations succeed or fail based on consumer adoption. In a closed proprietary system, the innovator will either be permitted or prevented from deploying based on the decision of the incumbent controller of the network, whose incumbency at the moment of decision is a historical contingency rather than the function of present innovativeness. The capacity of the owner to exclude unwanted innovations without itself being presently innovative is a factor in the extent to which the monopolist is or is not threatened by entrants into investing in innovation.

Welfare optimization – While much of Part IV was devoted to describing the comparative welfare implications of each approach, there is a separate element of welfare optimization that merits separated note. A particular type of constraint on the ability of spectrum property based systems to price efficiently has to do with the difference in their investment structure. As Part IV explains, open wireless systems are built of end user equipment designed to optimize end user capacity to communicate, while owned networks rely on greater investment at the core of the network in terms of designing capacity optimization and pricing. A consequence of this differential investment pattern is that open wireless networks are likely to adapt more rapidly to changing consumer preferences than proprietary networks.

⁴⁷ For a compact review of this literature see F.M. Scherer, *Schumpeter and Plausible Capitalism*, 30 *Journal of Economic Literature* 1416-33 (1992). Examples include Partha Dasgupta and Joseph Stiglitz, *Industrial Structure and the Nature of Innovative Activity*, 90 *Economic Journal* 266-93 (June 1980); Paul Romer, *Endogenous Technological Change*, 98(5) *Journal of Political Economy*, S73-S74 (1990); Glen C. Loury, *Market Structure and Innovation*, *Quarterly Journal of Economics* 93 (1979); F.M. Scherer, *Nordhaus's Theory of Optimal Patent Life: A Geometric Reinterpretation*, 62 *Am. Econ. Rev.* 422-427 (1972).

⁴⁸ For a recent model and comprehensive empirical testing of the Schumpeterian hypothesis see Philippe Aghion *et. al.* *Competition and Innovation, an Inverted U Relationship* (working paper, February 2002).

Posed with the need to invest in infrastructure and in a system to collect information about preferences and to minimize transaction costs associated with satisfying them, proprietary network owners must make decisions regarding for what they will optimize the network and pricing schemes. If SMS messaging is the big thing today, and the network provider believes that mobile gaming is the killer app of tomorrow, then the provider will design the network to serve the present and expected future applications best. If it turns out that some portion of the population, immediately or thereafter, wants to use the system to compare live feeds of traffic from automobile-mounted webcams, and the system does not price or service that use well, the operator will have to recognize that use, compare it to others, and optimize equipment within the network to service and price it. The lag between the redesign of the network and the contracts and the changing needs of consumers is a source of welfare loss. Anyone who is skeptical about this difficulty should spend some time at a conference where wireless mavens try to ponder what on earth 3G networks will be good for and how providers can design their networks to serve that good.⁴⁹

Open wireless systems, on the other hand, are built by equipment manufacturers that capture the future communications value embedded in the equipment at the moment of sale. To do so, they are likely to design flexible devices that can adapt to give their owners whatever utility the owner wishes over time. That is precisely the value embedded in general purpose computers, and it is precisely this agility and built-in capacity to be repurposed by the user as the user's preferences change over time that has driven the value of the computer market. What began as a spreadsheet calculator has transmogrified for many people into a communications device, a family album, and/or a game console, all rolled into one. Wireless equipment manufacturers too will try to embody as great a future value as possible in the equipment, in order to enhance its value to users. To the extent that innovation and changing possibility sets lead consumers to have rapidly evolving preferences, a system that allows users dynamically to utilize the networks for whatever they deem best will enhance welfare as compared to a system that requires some centralized decision to shift optimized uses to fit demand, and will always be hampered by costs of information collection about changing demand and the redesign time lag.

Security – In the context of communications networks in general, and wireless networks in particular, security usually arises in the context of three questions: how easy it is to cause the network to collapse, how easy it is to infiltrate and eavesdrop on the network, and how readily available it is for security forces to use in emergencies.

⁴⁹ See, e.g., the agenda for the excellent conference at Columbia Business School's CITI, Mass Media Content for Wireless Communications, Monday, April 5, 2002, available <http://www.citi.columbia.edu/>.

The Internet and the encryption debates of the 1990s have shown us that there are real tradeoffs between closed proprietary and open networks in these regards. While it is hard to specify which approach will be better under all conditions, open networks have important characteristics that could make them more, rather than less secure than closed networks. First, because open networks rely on densely deployed, self-configuring, decentralized mesh networks, physically bringing down the network is extremely difficult. On September 11, 2001, for example, traditional telephone networks were overloaded, New York City's public radio station was down, but email, instant messaging, and IP-based voice communications applications like NetMeeting were functioning. High-speed data connections were available downtown for the first few weeks only by using WiFi networks.⁵⁰ The basic characteristic of the Internet's robustness—its redundancy and decentralized architecture—is replicated in open wireless networks at the physical layer of the communications infrastructure. Second, communications that rely on processing gain and encryption are much harder to tap and infiltrate than communications that use high power communications. They are widely deployed by the military, which, of course, cannot assume that its enemies will comply with FCC regulations as to spectrum use, and so must design its systems for environments where no one has exclusive control over spectrum. Third, both of these characteristics also suggest that widespread deployment of redundant, robust communications networks that rely on encryption will actually provide a more robust system for public security communications in time of emergency than approaches that rely on proprietary or regulated control over specified blocks of spectrum, which depend on infrastructure that can be bombed or communications protocols that can be jammed. The physical infrastructure of an open wireless network will be more robustly and ubiquitously available and the platform it will offer will be less susceptible to jamming. All that needs to be implemented, if anything need be done, is to build into the network protocols an ability to recognize an emergency signal and give it precedence to overcome the potential for latency.

VI. POLICY RECOMMENDATIONS

The conclusion of my analysis suggests that there are strong reasons to think that permitting the operation of open wireless networks will be a superior approach towards wireless communications than creating an exhaustive system of property rights in spectrum. Nonetheless, the reasons to think that an equipment market based on open wireless policies will be better than an infrastructure market based on property rights in "spectrum allocations" are not *a priori* determinative. This leaves us, as a polity, in a position of doubt, not knowing which of two policy alternatives is

⁵⁰ Peter Meyers, In Crisis Zone, A Wireless Patch, NYT Oct. 4, 2001, Sec. G, p. 8., col 1.

preferable, yet convinced that one, or the other, or some combination of the two is likely to be dramatically better than the present regulatory system. Under these conditions, it seems that the most prudent course would be to begin to transition away from the present system by setting up a sufficiently robust experiment with both approaches that experience over the next few years will provide useful information about the longer term choice, while preserving our institutional freedom to abandon the experiment that failed, or to adjust the relative importance of either approach based on its relative success or failure. The elements of such a framework would include

- Creating a commons of sufficient magnitude and stability to allow a credible investment effort by toolmakers—equipment manufacturers and software companies—in building the tools that can take advantage of an ownerless wireless infrastructure
- Implementing some flexible property rights on a more limited and experimental basis than proponents of the Big Bang approach propose
- Building into both systems recovery options designed to permit policy to abandon or scale back either alternative, should experience suggest that one is decisively superior, designed so as to minimize the effect of potential future abandonment on the efficiency of current pricing of spectrum rights or on investment incentives in the equipment market

Expanding the Commons

- Revising 5 GHz range
 - The U-NII Band, the Unlicensed National Information Infrastructure band as it was called, was initially designed with very tight constraints based on the perceived needs of incumbent services. This, predictably, led to its underutilization, in particular use of the lower 200 MHz of that 300 MHz band has been curtailed by excessive solicitude towards incumbents
 - Regulation of the entire 300MHz in the U-NII band should be harmonized up, towards the most permissive regime possible given the constraints of open wireless network equipment, not the constraints of incumbents
 - To the extent possible, licensed users of that band should be cleared to increase the amount of contiguous high-frequency spectrum available
- Permitting unlicensed operation below 2GHz
 - Communications that use lower frequency electromagnetic radiation have the physical characteristic that they are unaffected by walls and leaves. Whether open wireless network equipment is permitted to operate below the 2GHz range or not will therefore affect the price and efficacy of

deployment of such networks. Below that range, devices generally need not have a line of sight in order to cooperate. Above it, they generally do. Devices that are limited to talking to other devices to which they have a clear line of sight will likely require external antennas to be efficient. This, in turn, suggests that they will need professional installation, encounter difficulties with roof rights in urban areas, and suffer substantial limitations on the extent to which devices can participate in adding to network capacity rather than simply using capacity. These are not theoretical constraints, but rather practical marketing constraints based on whether the device is as simple to deploy out of the box as a computer, or whether it requires substantial expertise to deploy.

- One plausible space for such a dedication is the 700MHz band of UHF channels that was slated for auctioning, but for which there was so little demand given the present state of capital markets that the auctions were called off. These channels have always been explicitly dedicated to the public interest, and have been thoroughly underutilized. The dedication should be understood as not only part of infrastructure policy, but also of universal service, as it promises to deliver substantial improvement in low cost, high bandwidth connectivity for both schools and rural areas.
 - There is strong resistance to this spectrum being auctioned now, because potential purchasers do not have the capital to purchase the licenses should they be auctioned now, and its dedication to a public, open use would be clearly consistent with the conception of the traditional role of the broadcast spectrum in fostering diversity of opinions and an open public discourse
- Two models for the dedicated bands. The frequency bands dedicated in the 5GHz range and below 2GHz could be structured along one of two alternative institutional models, or a mix of both. The first could be an approach that has been called by some “Part 16” and by some “meta Part 68”, both names of non-existing equipment certification procedures at the FCC that evoke Part 15 and Part 68 as baselines. The second would be the creation of a private, non-governmental public trust that will function as a standards setting organization to manage the commons. In the most general terms, these approaches require
 - Part 16/meta-Part 68
 - FCC certifies equipment as a type for utilization in the band
 - Certification is for compliance with generally applicable minimal non-harmfulness requirements
 - The requirements will be based on the needs of open wireless network equipment, not on protecting incumbent services from interference—this is the most important modification that “Part

16” provides over “Part 15”, under which devices are permitted to operate under very tight power constraints

- This caveat is a crucial improvement over current constraints, which define the operating characteristics based on the needs of old incumbent devices, not on preventing behaviors that could harm the new devices. If we are to have an effective test of open wireless networks, we must find spaces where they can function under their own constraints, rather than under the constraints of outmoded incumbents.
- To avoid reintroduction of FCC command and control regulation through the equipment certification process, it should include fast track approval for all equipment complying with standards set in open standard setting processes.
- Public Trust
 - The spectrum would be donated into a nongovernmental body, roughly akin to conservation trusts, whose charter would require it to permit operation of any and all devices that meet minimal sharing standards to be set in an open professional standards setting process, along the lines of the W3C or the IEEE.
 - The trust will be funded by fees paid by members on the W3C model, not from spectrum usage fees
 - The trust’s certification and standards decisions will be relatively insulated from regulation by either regulatory agencies or judicial review by treating the trust’s control over “its” frequencies as equivalent to the decisions of a private licensee in the most flexible licensing frameworks, or of a spectrum property owner should any bands be transitioned to that model
- Permitting commercial utilization of the amateur experimental bands
 - Ever since the 1920s, the FCC’s regulatory approach has been to leave high frequency bands not yet easily utilized in commercial applications for unregulated experimentation by amateurs. Because of the historical role that amateurs have played in the development of radio technology since the end of WWI, however, experimentation has been permitted solely to amateurs. Experimentation with commercial services is prohibited. At this stage of technological development, however, this is an unnecessary, and indeed technology-retarding constraint. If commercial enterprises are willing to risk research and development funds on experimenting with the development of open wireless networks in the very highest frequencies, they should not be prohibited from doing

so. If they succeed in finding efficient ways to use these higher frequencies, above 50GHz, given an absolutely unregulated environment and the co-presence of amateur experimentation, they should be permitted to sell equipment utilizing those frequencies.

- This utterly unregulated space could provide a testing ground for the plausible, but not necessarily highly probable claim that open wireless networks can thrive in a completely lawless environment.⁵¹ The claim is based on the observation that the techniques underlying open wireless networks have been in military use for decades, and that military uses assume a hostile environment of purposeful jammers and eavesdroppers, perhaps even more hostile behavior than is likely to occur in an unregulated commercial environment. Since the military has in fact succeeded in developing high-speed wireless communications systems that are robust to such hostile environments, there is no reason to think that, in principle, the same could not be done for commercial applications in an entirely unregulated space. Whether this can be done on a cost effective basis, given the price sensitivity of consumers as compared to the military, on the one hand, and the scale on which private market devices are deployed (millions of units) as opposed to military devices (tens, hundreds, or at most thousands of units) remains to be seen. The upper ranges of frequencies could, in any event, provide the locus for such experimentation.
- Permitting underlay and interweaving rights
 - Separate from any specific band designations, we should introduce a general privilege to transmit consistent with the basic principle that non-interfering uses should be permitted wherever possible.
 - The specific requirement here would be to revisit the FCC's UWB Order (Ultrawideband) and the SDR (software defined radio) process, so as to, in each case, expand to the extent possible the permission for wireless devices to use any frequency they wish as long as they comply with one of two basic constraints
 - The devices operate at a level of power that is so low that it does not appreciably affect the information flow rate of licensed incumbent devices deployed on the day of the approval. All licensed devices introduced thereafter will not be protected if designed to be less robust to interference from underlay devices than the incumbent devices were.

⁵¹ This insight is Tim Shepard's, made at the Open Spectrum Project meetings and on its list.

- The devices implement an automated carrier sensing process that allows them to sense the presence or absence of radiation in a band, and to recognize radiation from the licensed owner of the band they are using. The devices must automatically vacate the frequency upon sensing an attempted use by the licensed owner of the frequency. This would assure that these devices only use frequencies when the licensed owner is not attempting to use them. Because “spectrum” is perfectly renewable and reusable with no degradation, such use imposes no cost on the licensed owner, but offers socially valuable communications capacity.

The overall system of interlocking components of the spectrum would look roughly as described in Figure 10.

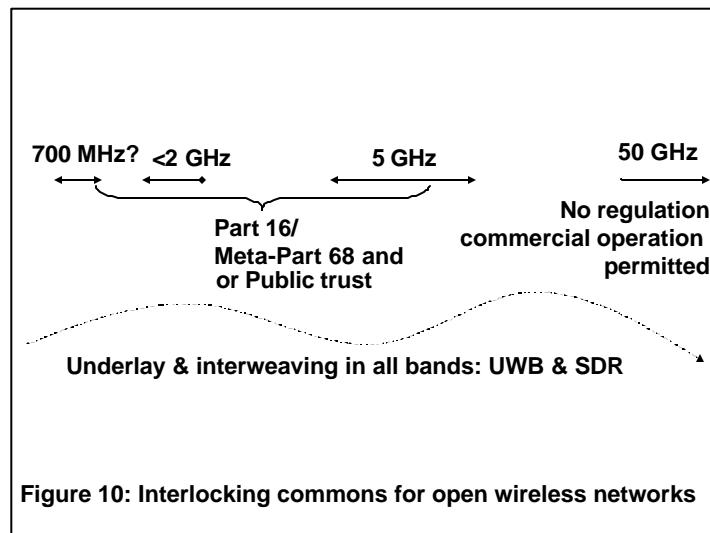

Experimenting With Spectrum Rights

In a similar fashion, we should work to identify a series of ranges of frequencies that have roughly similar propagation characteristics, and that could be subject to greater flexibility along roughly the lines proposed in the Big Bang auction. The spectrum needed for this experiment will be easier to locate and clear, because the experiment will represent a windfall to the incumbent licensees, wherever it is located. The big bang auction design is intended to create incentives for incumbent licensees to participate. To do so, it gives licensees a right to all the money paid at the auction,

and gives them a choice between, on the one hand, not placing their rights up for auction and retaining the precise contours of their license, and on the other hand placing their licensed spectrum up for auction but retaining a right to refuse to sell if the bids do not meet their reservation price. This option makes the licensees strictly better off by being designated as eligible to participate.

The primary institutional design question here, then, is how to experiment with the spectrum property idea without imposing too great a difficulty on reversing course in a few years, if our experience with the two systems strongly suggests that the preferable solution is to have less property in spectrum and more open wireless networks. The concern, of course, is that should property rights be created in too much spectrum, their incumbents will prove very difficult to clear to make way for open wireless networks. A parallel right to redesignation should be implemented for the spectrum commons bands should the opposite conclusion emerge from experience.

The institutional design should include two constraints. First, no more frequencies should be designated for the spectrum market experiment than necessary to make it viable. Certainly, this should be no more than the bandwidth set aside for open wireless networks, given that this approach is most effective at allocating narrow bands, whereas open wireless networks rely on wide bands as a baseline requirement.

Second, the property rights should include a recovery reservation, such that, should our understanding of the relative value of the approaches over time develop to favor much broader permission for open wireless networks, the cost of implementing the change will not be prohibitive. The trick will be to design the recovery system in such a way so as not to burden too much the present efficient pricing of the spectrum auctioned. The primary vehicle here could be to create a preset low cost buyback option in the government, that would allow the government the option to redesignate the frequencies to open wireless network use upon payment of a reduced recovery rate. The “redesignation” option, rather than a more generally defined repurchase option, is intended to prevent the government from simply speculating in spectrum, exercising the option and then selling back into a proprietary system. The exercise date must be set sufficiently far into the future that present discount rates in the wireless communications industry would make the discounted value of the option very low. 10 years may be a good baseline, but the precise term should be based on investment practices in the industry regarding when projected returns are no longer usefully considered in making an investment decision. The terms of the option would be set and known before the auction, so that no expectations are violated after the purchase of the rights. To prevent inefficient pricing over time as the exercise date grew near, Congress could create a periodic review process, whereby every three years, for example, Congress could decide to extend the option exercise period to the

original full period, to cancel the option, or to do nothing, and keep the option date unchanged. It would choose the first option if information was still lacking on the relative performance of the two approaches to wireless communications policy, the second if the spectrum property approach appeared to be better, and the third if open wireless networks seemed to be preferable. A similar redesignation caveat should be included in the instruments permitting various forms of open wireless communications equipment to function, adjusted to the discount rates in the equipment manufacturing industry, which is the primary industry whose investment incentives will be affected by the option.

CONCLUSION

Current wireless communications policy operates on technical assumptions largely unchanged since Marconi's time. While there is relatively widespread agreement that, at least from an efficiency perspective, the licensing regime that still regulates use of almost the entire usable range of frequencies is obsolete and should be abandoned, there is quite substantial disagreement over what its replacement should be. In particular, there are two primary alternative approaches. The first involves the creation of more or less perfect property rights in spectrum allocations, so as to allow bandwidth to be allocated based on market pricing of these exclusive transmission rights. The second involves the removal of current prohibitions on wireless communications equipment that prevent the emergence of open wireless networks built entirely of end user equipment.

The tradeoff between spectrum property markets and open wireless networks is primarily a tradeoff between the rate of increase in the capacity of the network and the efficiency with which a given capacity is allocated among competing uses. Spectrum property based markets are likely to grow capacity more slowly than open wireless networks. Because they will price usage, however, they are in theory likely, at least at peak utilization moments, to allocate the capacity they have more efficiently than would an open wireless network. Open wireless networks, however, are likely to increase capacity more rapidly, and if unconstrained by band use regulation, could increase capacity at the rate of growth of computation. Some research suggests that they may even be able to increase capacity proportionately with the increase of demand. Our experience in wired networks, both the public Internet and proprietary corporate networks, has been that strategies that have relied on rapid growth of capacity have been widely adopted, while strategies that assume slow growing capacity and seek efficiency through pricing to achieve quality of service assurances have not. It seems odd, in the name of the efficiency of markets, to adopt by regulation a system of property rights in spectrum that makes exactly the opposite choice than the one that users and corporations have made in the actual market

environment, when presented with a parallel choice in the context of unregulated wired networks.

At present, however, the lack of clear empirical evidence in favor of one or the other of the two radical critiques of the prevailing licensing regime cautions against any kind of “big bang” approach that will preempt future policy making. What we need is a relatively large-scale experiment in both markets. On the one hand, we should move to deregulate wireless communications equipment capable of functioning on the open wireless networks model. This move should be substantial enough to give equipment manufacturers a credible playing field for which to invest in equipment design, production, and marketing for ownerless networks. In parallel, it may be useful to permit some experimentation with spectrum property allocations, carefully designed so as to preserve longer term flexibility and avoid being locked in to the spectrum property model should open wireless networks prove to be the better approach.